

**Procurement Unit**  
**Request for Quotation**

**Date: Nov. 18, 2019**

CARE Afghanistan is a well-known organization working for reconstruction and rehabilitation of Afghanistan based on humanitarian assistance. CARE is determined to purchase its required goods/material/services for use of its projects. Please provide your most competitive quotation for the following items with consideration the terms and conditions stipulated below:

**Quotation for procurement of bellow services/items :**

- 1- Establishment of 90 Greenhouses by 210 Sqm (30 Kabul, 30 Balkh and 30 in Khost Provinces according to BOQ and Drawing bellow annexes :

**Note:**

- 1- An information session will be held on November 24 at 10:00 am in CARE, Kabul Main Office. Tenders are requested to attend the session to obtain information about tender and ask question if any. Please make sure you come 15 minutes earlier.

All tenders who are willing to participate in this session are kindly requested to share their names with us no later than November 21, 2019, otherwise they will not be allowed to participate in the session. (Please have your ID cards with you).

For enroll of participation in the above session, all interested suppliers can share their name and ID (tazkera) number along with name of related company through below e-mail address.

- 1- [Afg.Procurement@care.org](mailto:Afg.Procurement@care.org)
- 2- [Naeem.arbab@care.org](mailto:Naeem.arbab@care.org)

- 2- Suppliers are requested to write the subject and RFQ number on the top of envelop.
- 3- Please send a unique quotation.
- 4- Please note that only AFN Currency is acceptable.
- 5- Please note that, filling of Annex # Vi (**Declaration of Eligibility**) is mandatory.

For more detail please contact us with through e-mail address:

- 1- [Afg.Procurement@care.org](mailto:Afg.Procurement@care.org)
- 2- [Naeem.arbab@care.org](mailto:Naeem.arbab@care.org)

**نوت:**

۱- به منظور ارایه معلومات مفصل در مورد مناقصه و پاسخ به سوالات داوطلبان . دفتر پاملرنه از تمام متقاضیان تقاضا می نماید تا به مجلس ارایه معلومات و پاسخ به سوالات داوطلبان ساعت ۱۰ بجه قبل از ظهر مورخ ۲۴ نومبر سال ۲۰۱۹ عیسوی مطابق ۳ قوس سال ۱۳۹۸ هجری شمسی به دفتر مرکزی پاملرنه مراجعه نمایند. علاقمندان اشتراک در این مجلس لطفا شهرت خویشرا الی تاریخ ۲۱ نومبر سال ۲۰۱۹ عیسوی مطابق ۳۰ عقرب سال ۱۳۹۸ هجری شمسی با ما شریک سازند در غیر آن حق اشتراک در مجلس را ندارند. لطفا کارت هویت یا تذکره

خویشرا باخود داشته باشید. جهت ثبت نام برای اشتراک در مجلس علاقه مندان میتوانند شهرت خویش را با ذکر نام شرکت از طریق ایمیل ذیل باما شریک سازند.

- 1- [Afg.Procurement@care.org](mailto:Afg.Procurement@care.org)
- 2- [Naeem.arabb@care.org](mailto:Naeem.arabb@care.org)

۲- لطفاً نرخ های پیشنهاد شده خویش را به پول افغانی ارایه نمایید.

۳- لطفاً توجه داشته باشید که پر کردن ضمیمه شماره Viii (Declaration of Eligibility) الزامی است.

جهت معلومات مزید درمورد خدمات اعلان شده میتوانید از طریق ایمیل آدرس ذیل باما در تماس شوید.

- 1- [Afg.Procurement@care.org](mailto:Afg.Procurement@care.org)
- 2- [Naeem.arabb@care.org](mailto:Naeem.arabb@care.org)

#### **CARE Address:**

Haji Yaqoob Square, 1 street House # 242  
Shar-e-Naw, Kabul Afghanistan  
Phone: 0202201098  
Email: [Afg.Procurement@care.org](mailto:Afg.Procurement@care.org)

#### **CARE Afghanistan Annex # I-Summary**

**PR#000002823:**

S/N	Description	Location	Quantity	UOM	Unit Price	Total Price	Delivery Time	Remarks
1	Establishment of 210 Sqm Greenhouses in Kabul Province according to attached BOQ and Drawing	Kabul	30	NOs				
2	Establishment of 210 Sqm Greenhouses in Balkh Province according to attached BOQ and Drawing	Balkh	30	NOs				
3	Establishment of 210 Sqm Greenhouses in Khost Province according to attached BOQ and Drawing	Khost	30	NOs				
Grand Total								

#### **Background:**

##### **CARE International in Afghanistan:**

CARE is a non-governmental, non-political, non-profit, non-partisan and non-sectarian humanitarian organization, extending its relief and development assistance to those in need. CARE International in Afghanistan is a humanitarian and developmental organization that has been operational in Afghanistan since 1961. CARE in Afghanistan has been working in various sectors such as humanitarian, education, health, agriculture and rural development, sustainable livelihood, women economic empowerment, and inclusive governance.

##### **Livelihood Advancement for Marginalized Population (CARE/LAMP) project:**

Internally displaced people (IDP) and returnee settlements intensify unemployment in urban centers and peri-urban areas. Unemployment has already been a pervasive problem in Afghanistan, partially because of decades of conflict and political instability. Given the unstable situation, an

abnormally high number of households are on the move. It is clear that unemployment is a more prevalent problem in urban centers where larger numbers of eligible workers are competing for jobs and livelihoods. The urban unemployment problem is further exacerbated in many urban centers that serve as “settlements” for IDPs and refugee returnees.

Persistence of unemployment/underemployment, inadequate ownership of productive assets and services for women, gender inequality, and women and youth disempowerment especially for IDPs and returnees is driven by a merit of social, cultural, economic, and political factors, enduring change for the IDP/returnee women, men, and youth coupled with a socio-political context that ranges from unstable to hostile requires a comprehensive approach that integrates technical interventions while also investing in social, economic, and institutional capital development along with job creation and workforce connections.

Given the context described above, LAMP will position itself within urban areas and peri-urban areas in Kabul, Khost, Ghazni and Balkh provinces in order to provide ongoing support to enable IDPs and other marginalized populations to identify and secure sustainable livelihoods using the following approaches:

Through the Livelihood Advancement of Marginalized Populations (LAMP) project, CARE will create job opportunities and address the constraints to marginalized populations -Internally Displaced People (IDP), returnees, women, and youth-from securing jobs and business opportunities.

### Project Goal:

The overall goal of the livelihood advancement for marginalized populations LAMP project is to create sustainable jobs and livelihoods for IDPs, returnees, and some local households in the target urban centers in Afghanistan.

### Project Objectives:

- skills and experience to compete in urban center job markets by supporting non-agriculture-related value chain development and engagement.
- Promote an enabling environment to address specific systemic constraints to sustainable livelihoods faced by IDP and marginalized populations.

### Annex # II-BoQ

Bill of Quantity for Establishment of 210 Sqm (7m x 30mx3.5m) Greenhouse						
A	Descriptions	Quantity	Unite	Unit cost	Total cost	Remark
				AFG	AFG	
<b>1.00</b>	<b>Skeleton Materials</b>	<b>1.00</b>	<b>Structure</b>			
1	Pipe (Galvanize) for arch 1.5 inch (IS standard)	34.5	pc(6Meter)		-	
2	Pipe (Galvanize) 2 inch for Stand 70 cm (IS standard)	3.0	pc(6 meter)		-	
3	Supporter Pipe (Galvanize) 3/4 inch Horizontal for side of greenhouse (IS standard)	43.0	pc(6Meter)		-	
4	supporter Pipe (galvanized) 1 inch Horizontal	15.0	pc(6Meter)		-	
5	handle for ventilation	4.0	pcs		-	
6	Pin Joint (galvanize)	120.0	Pcs		-	
7	Four Joint (Galvanize)1,25x1/2 inch (IS standard)	11.0	pc(1/4Meter)		-	

8	clamp ( (Galvanize) for pipe 1.5 inch (IS standard)	65.0	pc(1/4Meter)		-	
9	Polyester Wire 2.5 mm	1,000.0	Meter		-	
10	Wire (Galvanize) 2.5 mm	20.0	Kg		-	
11	Wire (Galvanize)1 mm	2.0	kg		-	
12	Nuts and Bolts 12 mm	1.3	kg		-	
13	Washer metallic 12 mm	0.3	kg		-	
14	Cement for Concrete footing (26 pillar) as per drawing	5.0	Bags		-	
15	Crash and Gravel for Concrete footing of 26 pillar as per drawing	2.0	M <sup>3</sup>		-	
<b>2.00</b>	<b>Covering Materials</b>	<b>1.00</b>			-	
16	Plastic Sheet 180-200 mile micron Meter wide) with three 5% UV (10 years guaranty	31.0	Meter		-	
17	Plastic Sheet 180 mile micron 5% wide) for two side with UV (8 Meter three years guaranty	31.0	Meter		-	
18	(8 Plastic for door 180 mile micron Meter wide) good quality	8.0	Meter		-	
19	Screw nut for tying cover plastic with net (4 mm) 1 and 2 inch and Pine	3.0	kg		-	
20	Hose pipe for both side of Greenhouse 1/2 inch (plastic made)	26.0	Meter		-	
21	Insect Proof Net plastic (Grade 1) for ventilation of both side (4 Meter wide)	46.0	Meter		-	
22	GI clamp (Zawar) for plastic tie	250.0	Pcs		-	
23	Wooden sheet (3-4 cm wide ) chafti	160.0	Meter		-	
24	Profile (10x20x1mm) for net tie	6.0	PC ( 6Meter)		-	
25	wooden sheet (10 X3 cm) for fixed plastic sheet with GI pipe )	60.0	Meter		-	
<b>3.00</b>	<b>Slide Door Installation</b>	<b>1.00</b>			-	
26	Tube (Profile) 25X50X2mm for door rigid panel and frame See Drawing	2.0	pc(6Meter)		-	
27	C-Chanel 40X30X3mm on Top and Bottom for sliding doors See Drawing	1.0	pc(6Meter)		-	
28	Roller metallic 2 inch	4.0	pcs		-	
29	Handle metallic and lockset metallic for slide door	1.0	pcs		-	

30	lock metallic for slide door	1.0	pcs		-	
31	Anti rust for slide door	1.0	Can		-	
32	Insect Proof Net plastic (Grade 1) for slide door (4 Meter wide)	1.0	Meter		-	
<b>4.00</b>	<b>Double Door Installation</b>	<b>1.00</b>			-	
33	Angle 50x50x2mm	4.0	pc(6Meter)		-	
34	Profile (25x50x1mm) for door	3.0	pc(6Meter)		-	
35	Insect Proof Net plastic for door (4 meter wide)	8.0	Meter		-	
36	Handle metallic for door	1.0	pcs		-	
37	Lock metallic for door	1.0	pcs		-	
38	L Bow two Joint metallic	1.0	pcs		-	
39	Three-Joint metallic	2.0	pcs		-	
40	Hinge (metallic)	2.0	pcs		-	
<b>5.00</b>	<b>Stand For Water Reservoir</b>				-	
41	Angle Iron 60X60X4mm for Stand (see the drawing)	32.0	Meter		-	
42	Angle Iron 40x40x3mm for X bracing (see the Drawing)	62.0	Meter		-	
43	Angle iron 30x30x3 mm for X bracing ( see the drawing)	18.0	Meter		-	
44	Wooden plate (125X240X 3mm) under water tank (see the drawing)	8.0	Meter		-	
45	PCC 28 Map for water tank footings ( see the drawing)	0.7	M <sup>3</sup>		-	
46	Landscape plastic water tank 1000 litter Good Quality	1.0	pcs		-	
47	Pipe plastic Yellow 1 inch (Good quality)	50.0	Meter		-	
<b>7.00</b>	<b>Irrigation System Materials</b>	<b>0.00</b>			-	
48	HDPE Pipe 1 inch	25.0	Meter		-	
49	HDPE Saddle Clamp 32x20mm	14.0	Pcs		-	
50	HDPE Elbow 32mm	4.0	Pcs		-	
51	HDPE End Cap 32mm	2.0	Pcs		-	
52	HDPE M.T.A 32mm	4.0	Pcs		-	
53	HDPE F.T.A 32mm	4.0	Pcs		-	

54	HDPE Valve 32mm	1.0	Pcs		-	
55	filter 1 inch	1.0	pcs		-	
56	Start Connector 16mm	14.0	Pcs		-	
57	End Cap16mm	14.0	Pcs		-	
58	Valve 16mm	16.0	Pcs		-	
59	Clip 16mm	32.0	Pcs		-	
60	White Tap	4.0	Pcs		-	
61	LLDP Pipe 16mm 20x20 cm hole	300.0	M		-	
62	PVC Brushing for Water Tank 1"	3.0	Pcs		-	
<b>8.00</b>	<b>Miscellaneous</b>	<b>0.00</b>			-	
63	Greenhouse ground levelling cost	1.0	Lam		-	
64	Greenhouse installation, manufacturing and transportation cost	1.0	Lam		-	
<b>Total Cost in Afghani for One Greenhouse</b>						
<b>Total Cost in Afghani for 90 Greenhouses</b>						
Note all items must be deliver to target area(Kabul, Balkh,Khost) by vendor and determined quality ,made and specification of items which they bid for Greenhouse (7x30x3.5m) size.						

Annex # III- Drawing

CARE AFGHANISTAN  
KABUL OFFICE  
LAMP project  
ESTABLISHMENT OF GREEN HOUSE IN 210(7X10) M2 IN 10 SAP  
GREEN HOUSE ISOMETRIC VIEW

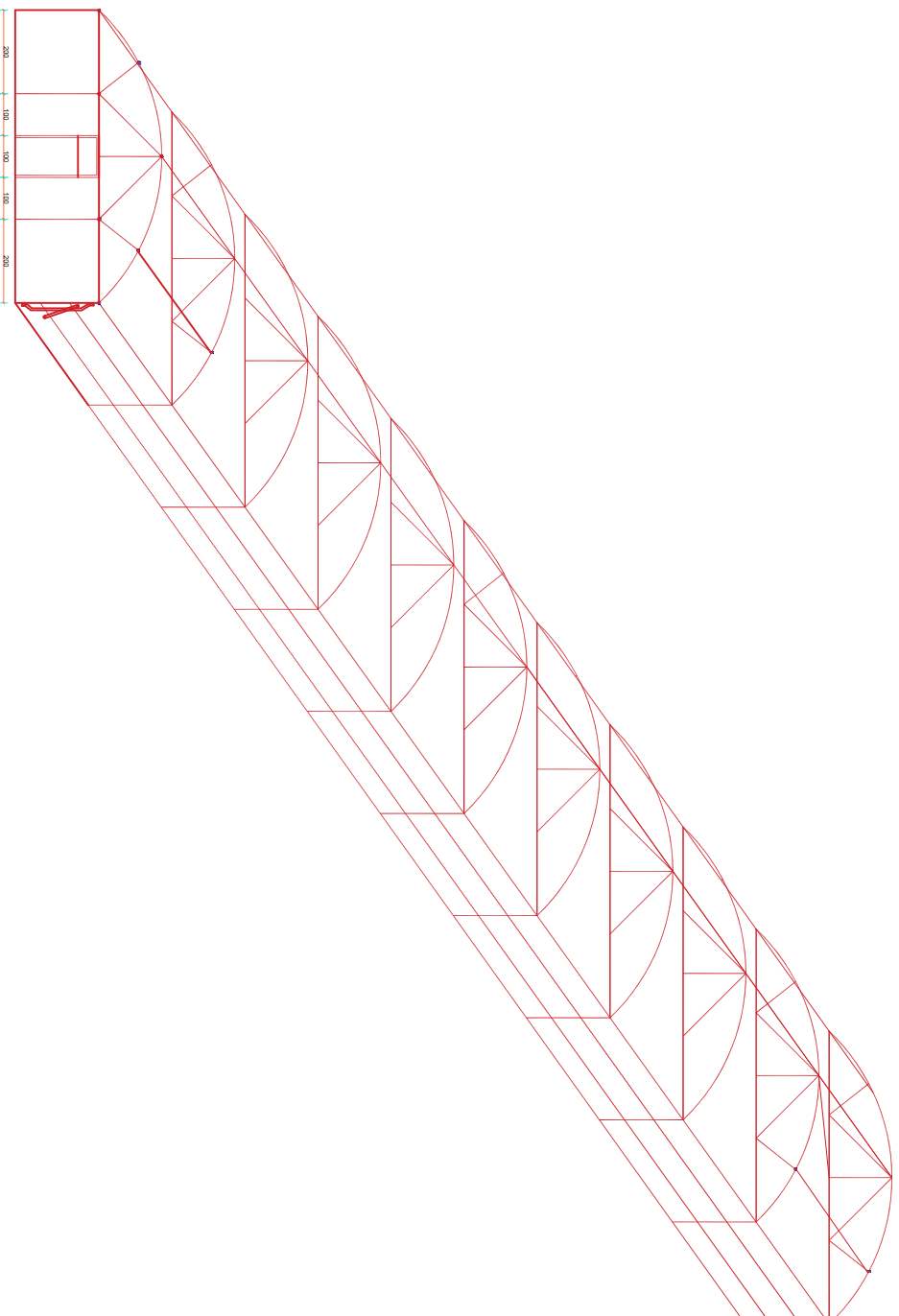



CARE AFGHANISTAN  
KABUL OFFICE  
LAMP project  
ESTABLISHMENT OF GREEN HOUSE IN 210(7X10) M2  
GREEN HOUSE PLAN AND LONGITUDINAL SECTION

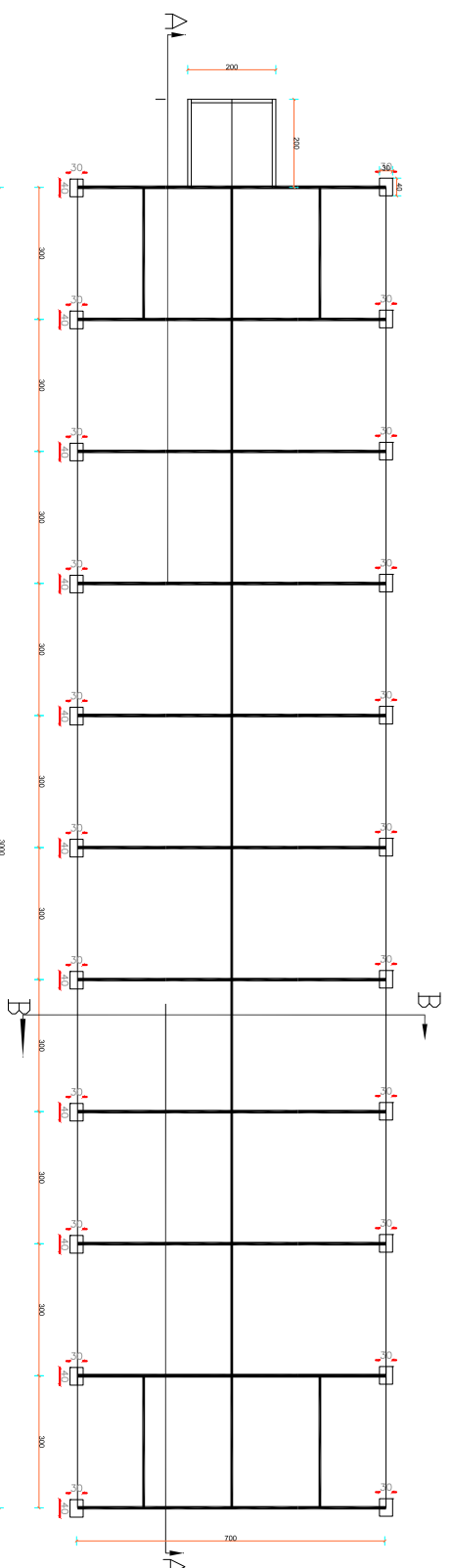

GREEN HOUSE LONGITUDINAL SEC A-A

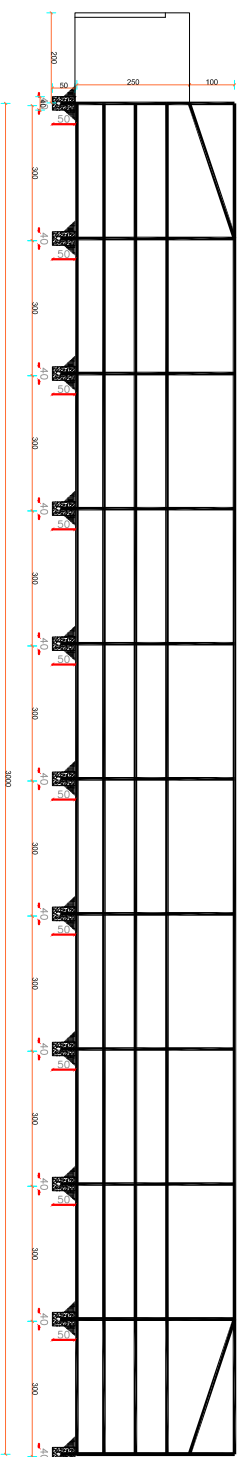

CARE AFGHANISTAN  
KABUL OFFICE  
LAMP project

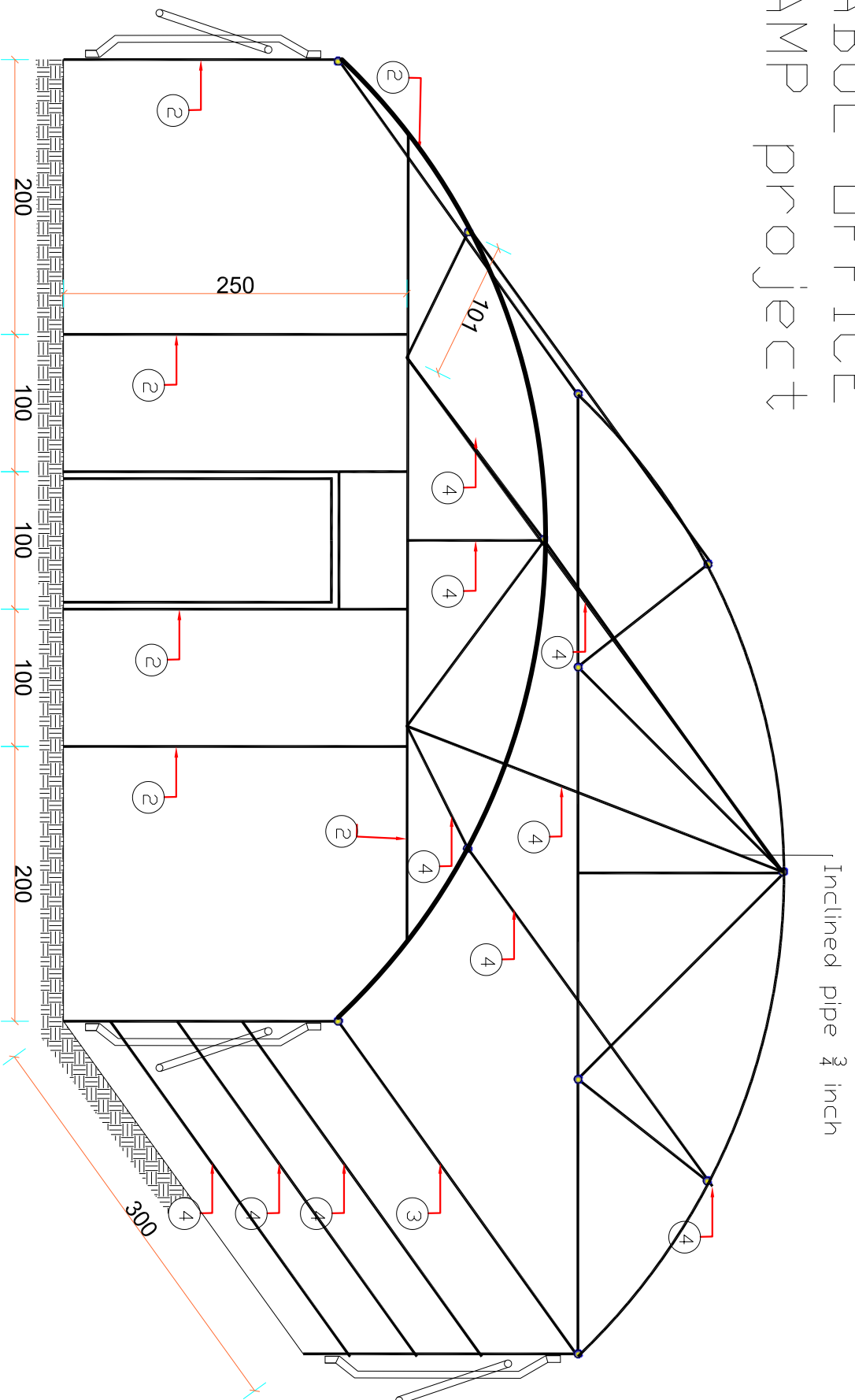

GREEN HOUSE FRONT VIEW WITH OUT, DOUBLE DOOR

CARE AFGHANISTAN  
 KABUL OFFICE  
 LAMP project

SEC: B-B

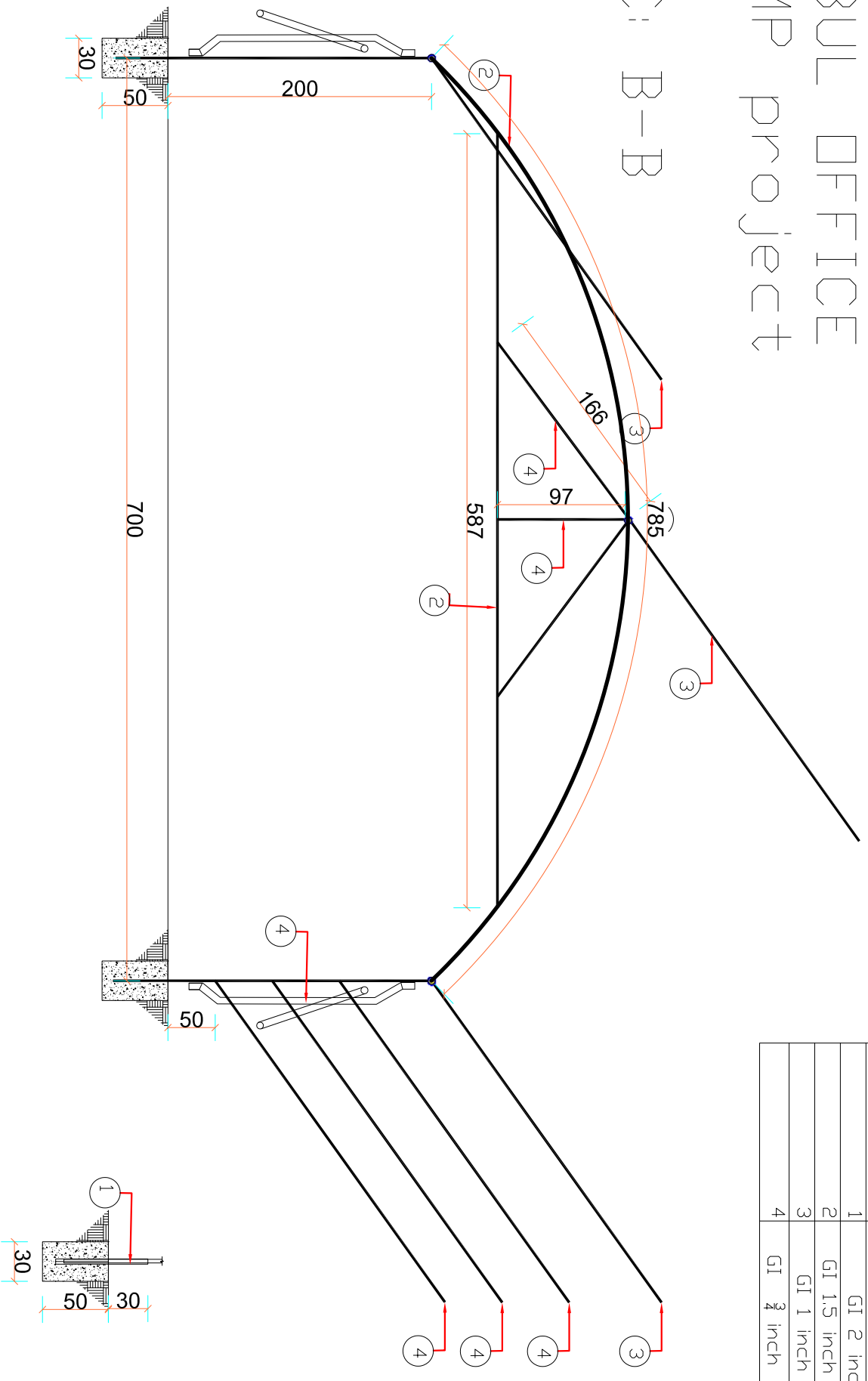

Pipe No	Pipe dia. in inc
1	GI 2 inch
2	GI 1.5 inch
3	GI 1 inch
4	GI 3/4 inch

GREEN HOUSE CROSS SEC B-B

HOUSE DEATAILS  
 Four Joint installed to each arch

Welded Joint set as pipe diameter and it is not welded longitudinal GI pipe Pin joint also install in every joint to all Arch

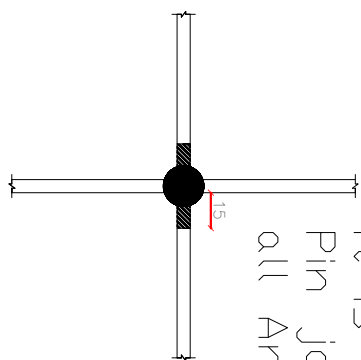
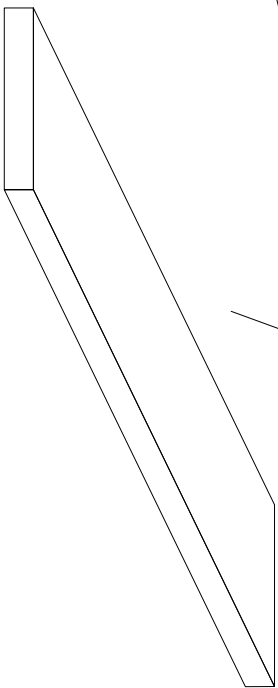
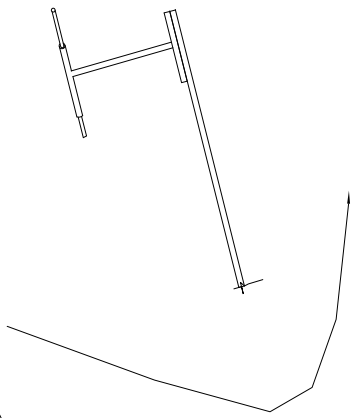

Wood plate with 10x3 cm width and thickness along green house ventilation and fit with GI pipe and plastic

Green house GI pipe number and total length with out estimation of joints

Pipe No	Pipe dia in inc	T.Pipe length (M)	Weight in kg/m	Unit	Remark
1	GI pipe 2 inch			M	
2	GI pipe 1.5 inch			M	
3	GI pipe 1 inch			M	
4	GI pipe 3/4 inch			M	

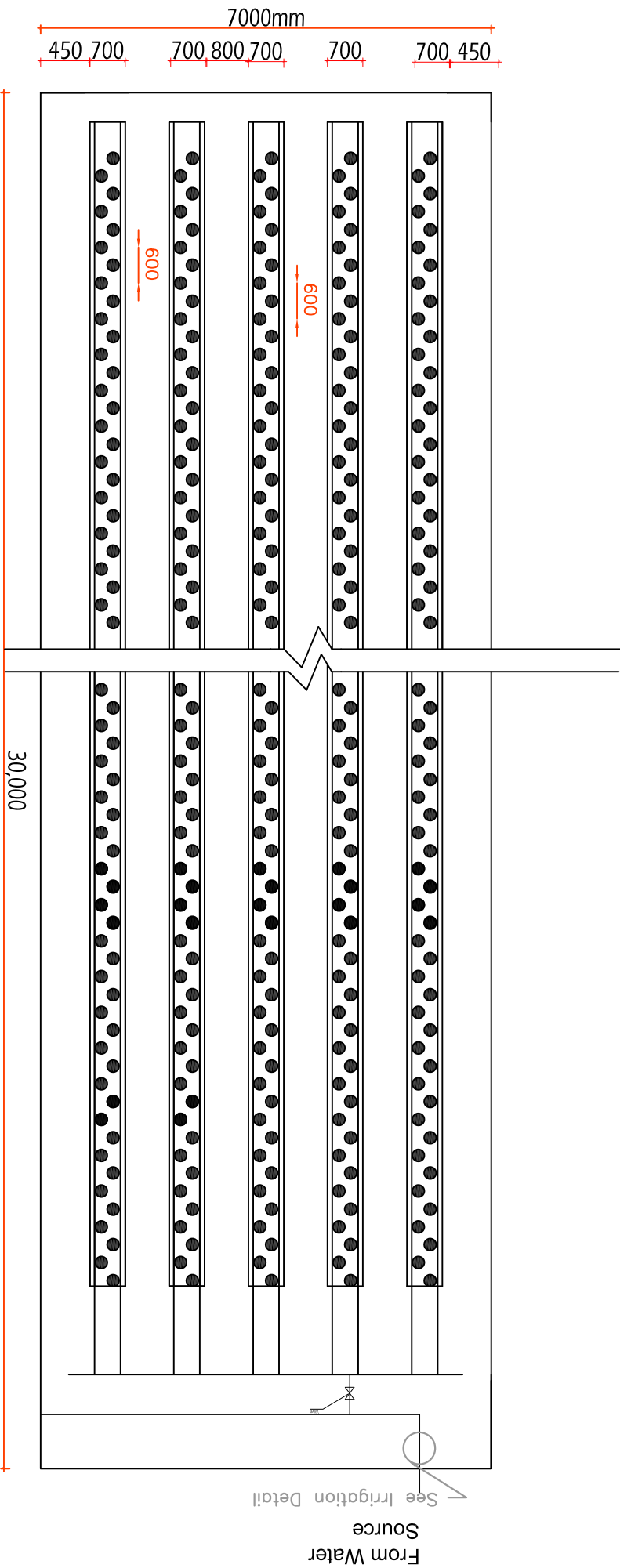

From Water

See Irrigation Detail

# Drip Irrigation Detail

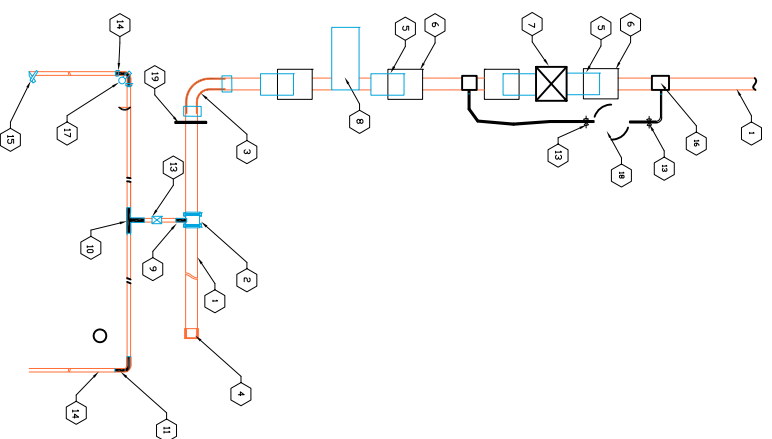

## KEY NOTE:

1. HDPE PIPE 1" 10 MPA
2. HDPE SADDLE CLAMP
3. HDPE L-BOW 90 DEGREE
4. HDPE END CAP
5. HDPE M.T.A
6. HDPE F.T.A
7. HDPE B-VALVE
8. HDPE FILTER LINE DISC STRAINER
9. START BARB CONNECTOR 16MM
10. TEE (T) JOINT CONNECTOR 16MM
11. L-BOW 90 DEGREE 16MM
12. END CAP 16MM
13. B-VALVE 16MM
14. PLASTICE/GALVANIZED CLIP 16MM
15. LLDPE PIPE 16MM 20X20 CM HDLE
16. LLDPE PIPE WITH DUT HOLES
17. PVC STICK 16MM
18. PVC BRUSHING FOR WATER 1"
19. GALVANIZED IRON STICK

NOTE: THE FERTILIZER TANK WILL SET AS NEED OF FIELD AND WILL NOT INSTALL AS DRAWING IT WILL CHANGE DURING IMPLEMENTATION

# Elevated Water Tank

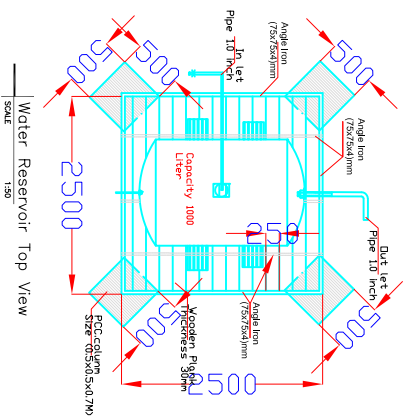
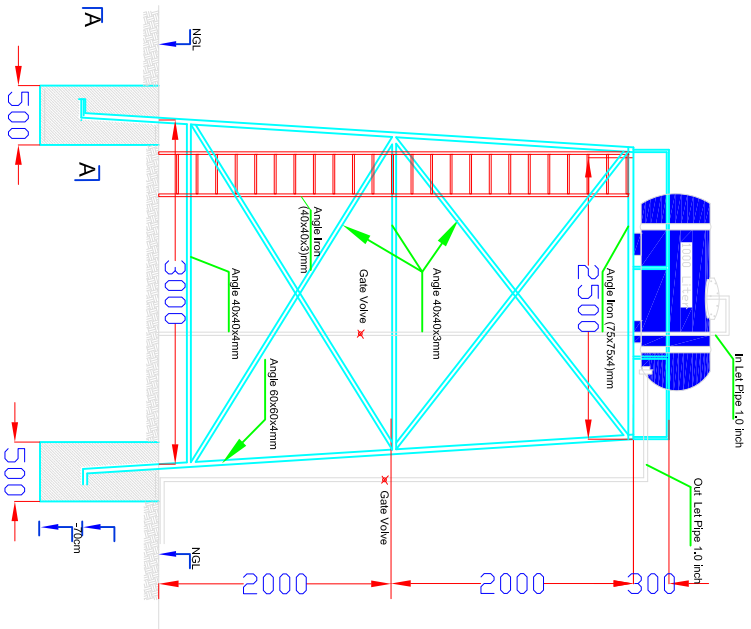

Water Reservoir Top View

DETAIL -A-A

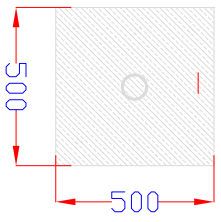

## Double Door Details and Slide Door Details

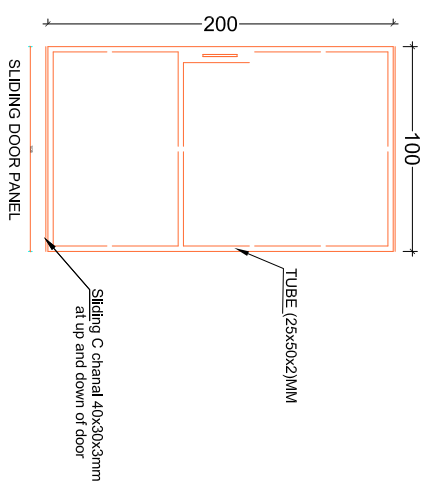
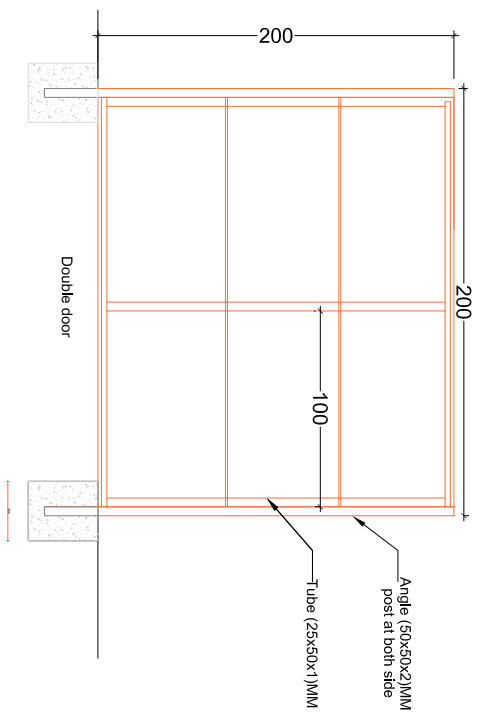



**Annex # iv**

**: Past Performance (only similar project Greenhouse Establishment )**

**Firm Name:**

*Note: Please don't change the format*

No	Project- Code	Project Title	Description of Activities	Location Province/ District	Client Name/Tel No/Email Address	Cost in AFN	Started-Date	Ended-Date	Type of contract	Remarks
1										
2										
3										
4										
5										
6										
7										
8										
9										
10										
11										
12										

Authorized Signature and Stamp

.....

## Annex # v

<b>Quotation Submission Deadline: (2<sup>nd</sup> December, 2019) Closing of business</b>
-------------------------------------------------------------------------------------------

The quotations received after 4:00pm on due date will be disqualified

### **Application Submission Requirements:**

#### **Applications shall be submitted in English language and it must include:**

1. Announced RFQ signed and stamped by firm.
2. Completed quotation/applicant
3. Completed past performance sheet (Annex #iv).
4. Completed Budget Annex I PRNO0000002823 Summary of Quotation Price
5. Other financial and administrative documentation required by the RFQ (it's kindly requested to DO NOT attach extra/irrelevant documents).
6. Please send update and valid license of your company as attachment of application.
7. Filled (signed & stamped) declaration of eligibility form.

#### **Please read the following terms and conditions carefully before submitting your quotations.**

- 1- Based on government withholding tax law, CARE will withhold 2% from registered and 7% from non-registered vendors. Due to unavailability of renewed licenses at CARE procurement unit, CARE will withhold 7% from the concerned vendor.
- 2- The suppliers should submit the details of their company – proof of registration, company history, company owners, and experience on similar bids.
- 3- Suppliers has to submit their “declaration eligibility” (See annex # VIII).
- 4- The quotation should bear price of each item separately and the quotation validity period to be specified clearly.
- 5- The quotation should be submitted as per specification or sample specified by CARE.
- 6- The delivery of sealed quotation to CARE office or putting it in a sealed box is vendor's responsibility.
  - a. The quotation should be dispatched on the official pad of the vendor. Vendors may be asked by our organization to submit additional information during the quotation evaluation.
  - b. Our organization has the right to reject all offers and /or to cancel the whole tender
  - c. Our organization has the right to negotiate the offers received.
  - d. Our organization has the right to increase /decrease the Quantities requested in the offer from the date of signing the Contract, without changing in the offered price reference will be made to the validity section.
- 7- The items will be acceptable only conforming to the specified specification given by CARE.
- 8- The vendor's company name and address should be posted at back of the quotation envelope.
- 9- The purchase contract will be awarded to the bidder whose quotation has been determined to be substantially responsive in terms of low price for the same quality, favorable delivery time, payment method and warranty.
- 10- Selection of the successful applicant will be based on the ranking of companies according to financial and technical criteria, as well as any other criteria suggested by the procurement Committee. Based on this our organization will then make a recommendation. Taking into consideration the recommendation of the procurement committee, our organization will make the final choice of the awarded company. Our organization will then send a letter of acceptance to the successful applicant. After all verifications, the company will then be asked to sign the contract for the stated amount. Any amendment to the awarded Quotations will be documented as an “Annex” to the contract and will be determined by our organization.
- 11- The delivery, transportation, insurance cost and any incidental charges such as (handling, packing, loading, unloading) of the requested item up to the specified location will be on the supplier's account.

- 12- Each bidder shall submit only one quotation.
- 13- The quotations would be evaluated for all items together or would be evaluated separately for each item.
- 14- The payment for purchased items will be done after delivery and certification by responsible person at the delivery point and submission of financial documents, as per CARE financial rules and regulations.
- 15- The delivery time of the specified items should be mentioned on the face of the quotation.
- 16- At the backside of the sealed quotation envelope it should be written **Quotation**.
- 17- After evaluation, only winning vendors will be formally notified. Opening of sealed quotation is the responsibility of the CARE procurement Committee; therefore the vendor should not disclose the rate stipulated in his quotation to any procurement staff/committee, before the procurement committee opens the quotations.
- 18- Attaching CARE's Request for Quotation (RFQ) is a must with the original quotation of the vendor.
- 19- CARE reserves the right to accept/reject part or entire of the requested items.

#### **CARE Standard Payment Term:**

1. CARE as a matter of policy will not pay a deposit or any form of advance payment to any supplier.
2. Withholding taxes will be deducted by CARE and it will be paid to government on behalf of the supplier as per current tax policy.
3. CARE will not entertain any changes in price after the tender has been awarded for whatever reason.
4. Price validity for goods and services supplied will be for the duration of the contract.
5. CARE reserves the right to reduce or delay payment to the supplier in the event that any of the contractual terms are not met in full or partly.
6. CARE reserves the right to ask the winning vendor to deposit 3% of the total contracted amount as a security deposit.
7. Payment will be made through wire transfer within 2 weeks after the submission complete financial documents.

### **Annex # Vi PURCHASE ORDER TERMS AND CONDITIONS**

**ORDER.** This Purchase Order ("Order") is an offer of Cooperative for Assistance and Relief Everywhere, Inc. ("CARE") to purchase the Goods described herein from Vendor. CARE's placement of this Order with Vendor is expressly conditioned on Vendor's acceptance of all of the terms contained in this Order, including without limitation, this Order shall not be filled at prices higher than stated in this Order or for different quantities. Any additional or different terms or conditions in any communication from Vendor are expressly objected to and are not effective or binding unless CARE agrees in writing, and no such additional or different terms are part of a contract between CARE and Vendor even if CARE accepts Goods under this Order. Any objection by Vendor to the terms hereof shall be ineffective and is deemed waived by Vendor when Vendor accepts this Order. Each Order terminates sixty (60) days after the Delivery Date, except as set forth herein or as CARE shall notify Vendor in writing. The Order Number above shall be shown on all invoices, communications, packing lists, containers, bills of lading and other similar documents.

**PRICE.** The prices stated in this Order are complete and Vendor shall add no additional charges of any kind. Vendor warrants that the prices to be charged for Goods are competitive with prevailing market rates and do not exceed prices charged to other customers for a similar quantity and quality of Goods. In connection with any cash discount specified in this Order, time will be computed from the date of the complete and final delivery of the Goods, or from the date correct final invoices are received in the CARE's Accounting Department, if later. Vendor shall specify all applicable costs, including taxes, duty, export and transportation fees and other charges on Vendor's invoice as separate items, and shall bear all such costs as part of the total Price charged.

**QUALITY.** Vendor warrants the Goods are (a) free of all deficiencies and defects in materials, design and workmanship for the period of one (1) year from the date CARE accepts the Goods, (b) does not infringe the rights of any third parties, and (c) are free of any lien or encumbrance. Vendor warrants it shall vest all title and rights to the Goods in CARE. If no quality is specified in this Order, the Goods delivered must be of the best quality as recognized by the market and conforming to or exceeding all specifications provided by Vendor.

**SHIPPING AND PACKING.** Unless otherwise stated in this Order, all Goods shall be shipped freight prepaid Delivery Duty Unpaid (DDU) Destination, and CARE will pay no charge for packing, boxing or cartage. Vendor is responsible for loss of or damage to any Goods before receipt by CARE at Destination. Each package of Goods will contain documentation showing shipper's name, contents of package, and the Order Number. A copy of the bill of lading, invoice, customs and import/export confirmations, or similar documentation shall be sent at time of shipment to CARE at the address stated in this Order as well as to the Destination, if different.

**DELIVERY.** Time is of the essence and delivery of Goods shall be strictly in accordance with this Order. Delays in shipment or otherwise shall be reported immediately to CARE, and the Order payment shall be subject to a late arrival penalty if specified on the Order. Partial deliveries may not be accepted; contact CARE in advance if a partial delivery is requested.

**INSPECTION AND ACCEPTANCE.** All Goods shall be subject to CARE inspection and test at any time and place, including at place of manufacture. Vendor will make available to the CARE inspectors copies of drawings, specifications, and processes applicable to the Goods and shall promptly provide CARE any resulting inspection certificates. Further, all Goods are subject to final inspection and acceptance at the Destination notwithstanding any payment or other prior inspections. CARE may reject and hold at Vendor's expense, subject to Vendor's disposal, all Goods not conforming to this Order or other applicable specifications, drawings, samples, or descriptions.

**DEFECTIVE WORK.** If any Goods are defective in material or workmanship or otherwise do not conform to this Order, CARE may: (a) require Vendor to repair or replace at Vendor's cost any such nonconforming Goods; (b) require Vendor to refund the price of any such Goods; or (c) elect to retain and correct any such Goods with an appropriate price reduction to offset CARE's costs of making correction(s). Nothing, including any final inspection, shall relieve Vendor from its responsibility to correct or replace Goods defective as a result of fraud, recklessness or latent defects.

**PAYMENT TERMS.** Invoices in duplicate are required. CARE will pay Vendor as specified in this Order, including pursuant to any discount terms; if no time of payment is indicated, payment shall be made within thirty (30) days after CARE accepts the Goods at the Destination. Any adjustments in Vendor's invoices due to shortages, late deliveries, rejection or other failure to comply with the requirements of this Order may, at CARE's option, be made by CARE before payment, but failure to do so shall not deprive CARE of the right to do so later. CARE may withhold ten percent (10%) from payment of the final invoice to ensure that all Goods conform to this Order and all necessary documentation has been properly received.

**CHANGES.** CARE may at any time make changes or amendments to this Order, but no such change or amendment will be allowed without the written authorization of CARE. CARE may also make changes in the method of shipping or packing and place of delivery by means of written communication (or, if accepted by Vendor, verbal communication) prior to shipment of Goods. If any such change by CARE affects the cost or delivery schedules of this Order, an equitable adjustment shall be made, provided Vendor makes a written claim therefore within thirty (30) days from the date of CARE's communication of the change.

**CARE NAME.** The Vendor shall not use the CARE name or trademarks publicity or publicly disclose information relating to the Order without CARE's prior written consent.

**COMPLIANCE WITH LAWS.** Vendor shall comply with all laws, regulations, and orders applicable to its performance hereunder

**INDEMNIFICATION.** Vendor will indemnify and hold harmless CARE and its related CARE entities from and against any claims, losses, damages, expenses, penalties, causes of action or liabilities arising from: (a) Vendor's breach by of any obligations or warranties hereunder, or violation of trade secrets, patent, trademark or other intellectual property rights, or (b) any other acts or omissions of Vendor, its agents, employees, subcontractors, or guests, relating to this Order. In no event shall CARE be liable for Vendor's lost profits or consequential or incidental damages. Any action by Vendor against CARE arising out of or in connection with this Order must be commenced within one (1) year after the cause of action has accrued or such action shall be deemed waived.

**ASSIGNMENT.** Vendor shall not assign this Order or any of its obligations hereunder, without the prior written consent of CARE.

**APPLICABLE LAW AND DISPUTES.** This Order, and the application and interpretation of any contract between CARE and Vendor arising in connection with this Order, shall be governed exclusively by the laws of the State of Georgia, U.S.A. if a US vendor, or CARE's preferred country if non-US vendor, without regard to its choice of law rules. The parties shall first try to resolve any controversy or claim arising out of or relating to this Order, or the breach or alleged breach thereof, by good faith negotiation among senior managers unrelated to the dispute, and failing that, by arbitration. The parties shall select a mutually acceptable arbitrator and work in good faith with the arbitrator to resolve the dispute. The location of the arbitration shall be Atlanta, Georgia. To the extent permitted by law, the arbitrator's decision shall be final and binding and may be entered in any court having competent jurisdiction.

**ENTIRE AGREEMENT.** This Order, together with its attachments, contains the entire agreement of the parties related to the subject matter hereof, and no other representation, inducements, promises or agreements, oral or otherwise, shall be of any force or effect. This Order may be supplemented, amended or modified only by written agreement of the parties. Each attachment is incorporated by reference herein and forms a part of this Order. If any provision of this Order or its application to any party or circumstances shall be invalid, illegal, or unenforceable to any extent, the remainder of this Order and its application shall not be affected and it shall be enforceable to the fullest extent permitted by law. This paragraph and paragraphs 8, 9, 13, 16 and 18 shall survive the completion or termination of this Order.

**CONDUCT.** Vendor and its employees shall maintain and comply with a written code of conduct that prohibits giving anything of value, directly or indirectly, to any person or entity, including government officials or CARE staff, in the form of a bribe or kickback; establishes appropriate limitations on transactions with relatives of Vendor employees or businesses or ventures related to Vendor or its employees; and otherwise properly governs the performance of its employees engaged in soliciting, awarding or administering contracts, and receiving gifts. Vendor shall inform CARE in writing of any violations relating to its obligations hereunder. Vendor certifies that it has not knowingly provided and will not knowingly provide, in violation of applicable laws, material support or resources to any individual or organization that advocates, plans, sponsors, engages in, or has engaged in an act of terrorism.

**TERMINATION AND DEFAULT.** In addition to any other remedy available by law or in equity, CARE may cancel this Order, in whole or in part, at any time by written notice to Vendor, including without limitation in any of the following circumstances: (a) Vendor failure to deliver the Goods as specified herein; (b) in CARE's good faith judgment, Vendor failed to perform, or jeopardized performance of, this Order in compliance with its terms, and did not cure such failure within ten (10) days after notice from CARE; (c) Vendor becomes insolvent or makes an assignment for the benefit of its creditors, or has bankruptcy, reorganization, readjustment of debt or insolvency proceedings instituted against it under law of any jurisdiction. On receipt of such notice, Vendor shall discontinue all work, cancel any sub-orders and terminate any subcontracts relating to this Order. Upon such termination, full and complete settlement of all Vendor's claims shall be made as follows: a) Vendor shall be paid full compensation for Goods conforming to this Order and materials relating thereto approved by CARE, such as work-in-progress, plans, drawings, and specifications, and b) title shall vest in CARE for all such Goods and materials for which CARE has paid.

**NON EXCLUSION:** I, the undersigned, declare on my honor that the company and the members of its Executive Board listed have not found themselves or have not been in any of the following situations: bankrupt or being wound up; been convicted of an offence concerning their professional conduct; been guilty of grave professional misconduct proven by any means which CARE can justify; have not fulfilled obligations relating to the payment of social security contributions or the payment of taxes in accordance with the legal provisions of the country in which they are established or with those of the country of the grant beneficiary (CARE) or those of the country where the contract is to be performed; have not been found guilty of fraud, corruption, involvement in a criminal organization or any other illegal activity detrimental to the institutional donor and/or CARE's financial interests; following another procurement procedure or grant award procedure financed by an institutional donor, they have been declared to be in serious breach of contract for failure to comply with their contractual obligations.

If this purchase or agreement is funded with US Government (USG) donor funds, certain donor requirements may apply. These requirements apply to Purchase Orders and Service/Consultant Agreements. Requirements for USG donors:

- 1) **Non-US Vendor:** All goods and services must originate from the host country and Vendor must be a citizen of that country, unless CARE otherwise approves in writing.
- 2) **US Vendor:** All goods and services must originate from the United States or the host country and Vendor must be a citizen of the US or that country, unless CARE otherwise approves in writing.
- 3) Vendor shall provide CARE with a report on or before April 1 of value-added taxes and custom duties (not sales tax) valued at \$500 or more charged by the government on purchases hereunder during the prior fiscal year (October to September), and any reimbursement of such taxes or duties by the government. Alternatively, Vendor may itemize such taxes and/or duties on individual invoices submitted to CARE.
- 4) This agreement shall be terminated immediately if the USG terminates or suspends funding to CARE. All goods or services rendered prior to that date will be paid to Vendor on a prorated basis.
- 5) During this agreement and for three years after it, CARE, the USG or their representatives on request may access and review any information and records of Vendor directly related to the agreement.
- 6) Vendor certifies that neither it nor its officers, board members or key staff is barred, suspended, proposed for debarment, ineligible, or otherwise excluded from doing business with the USG or its agencies or departments.
- 7) These provisions must be passed to Vendor's lower tier Subcontractors.
- 8) At CARE's request, Vendor shall sign any certificates or documents and such take actions as are required by the donor.
- 9) In addition to the foregoing, depending on the USG funding, Vendor is required to comply with the requirements contained in the following referenced publications
  - a) Non-US Vendor: Mandatory Standard Provisions. See <http://www.usaid.gov/policy/ads/300/303mab.pdf>.
  - b) US Vendor: 22 CFR 226 - Administration of Assistance Awards to US Non-Governmental Organizations (USAID).
  - c) U.S. Federal Acquisition Regulation ("FAR") at <http://acquisition.gov/far/index.html> [Vendor may be required to have additional insurance for its workers performing hereunder outside the US and provide CARE evidence of such insurance. USG waivers may be available if workers are not US citizens or residents and receive adequate protection.]
  - d) USAID Acquisition Regulation (AIDAR) at <http://www.usaid.gov/policy/ads/300/aidar.pdf>
  - e) Centers for Disease Control: [http://www.access.gpo.gov/nara/cfr/waisidx\\_07/45cfr74\\_07.html](http://www.access.gpo.gov/nara/cfr/waisidx_07/45cfr74_07.html) [Vendor cannot use funds provided by the USG to lobby for, promote or advocate the legalization or regulation of prostitution as a legitimate form of work. Vendor must obtain a written declaration to such an effect from its subcontractor(s).]
  - f) Bureau of Population, Migration and Population: [http://www.access.gpo.gov/nara/cfr/waisidx\\_09/22cfr145\\_09.html](http://www.access.gpo.gov/nara/cfr/waisidx_09/22cfr145_09.html)

Declaration of Eligibility

ANNEX # Vii

Name of Company:

---

I, the undersigned (*Name and address of representative*)  
Representative of

---

(*Name and address of company*)

Declare that the following conditions are applicable to us;

- We are registered companies.
- We are not bankrupt or in the process of going bankrupt.
- We have not been convicted for an offense concerning professional conduct.
- We have not been guilty of grave professional misconduct (proven by any means which the contracting authorities can justify).
- We have fulfilled obligations related to payment of any applicable local taxes.
- We are not guilty of serious misinterpretation in supplying information.
- We are not in situation of conflict of interest (with prior relationship to project or family or business relationship to parties on Commission).
  
- We were not declared as serious fault of implementation owing to a breach of their contractual obligations.
- We do not employ personnel below the legal working age.
- We provide basic social rights and fair working conditions to our employees.
- We are not on any list of sanctioned parties issued by the United States Government, United Nations and European Union.

In the presence of

Declared

---

(*Signature*)

---

(*Signature*)