

Latrine Block Plan

The latrine drawing is not representing all schools latrine block that will be rehabilitated and improved, Latrine blocks differ from school to school. The Contractor should check each Latrine Block before filling of the BOQ.

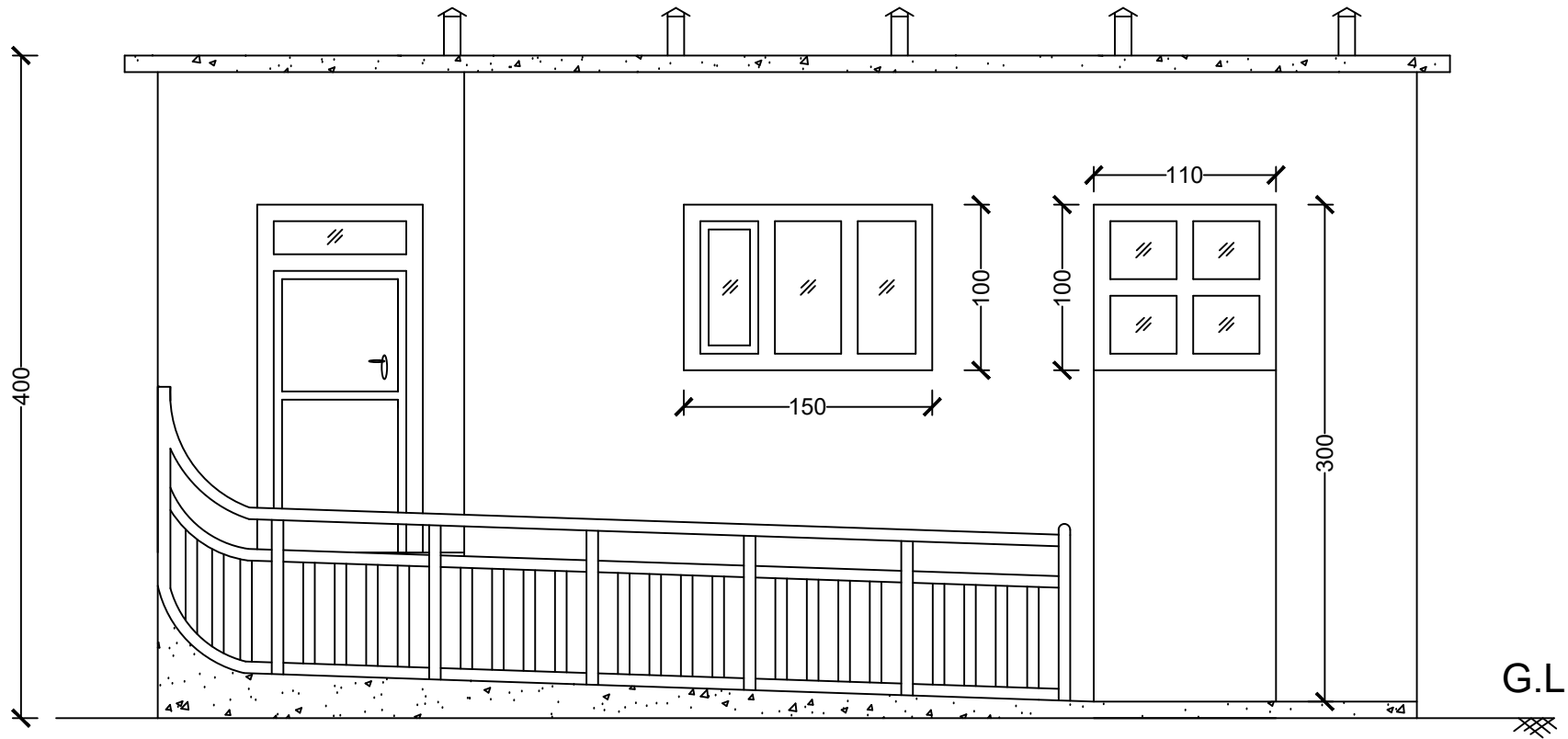

Front Elevation

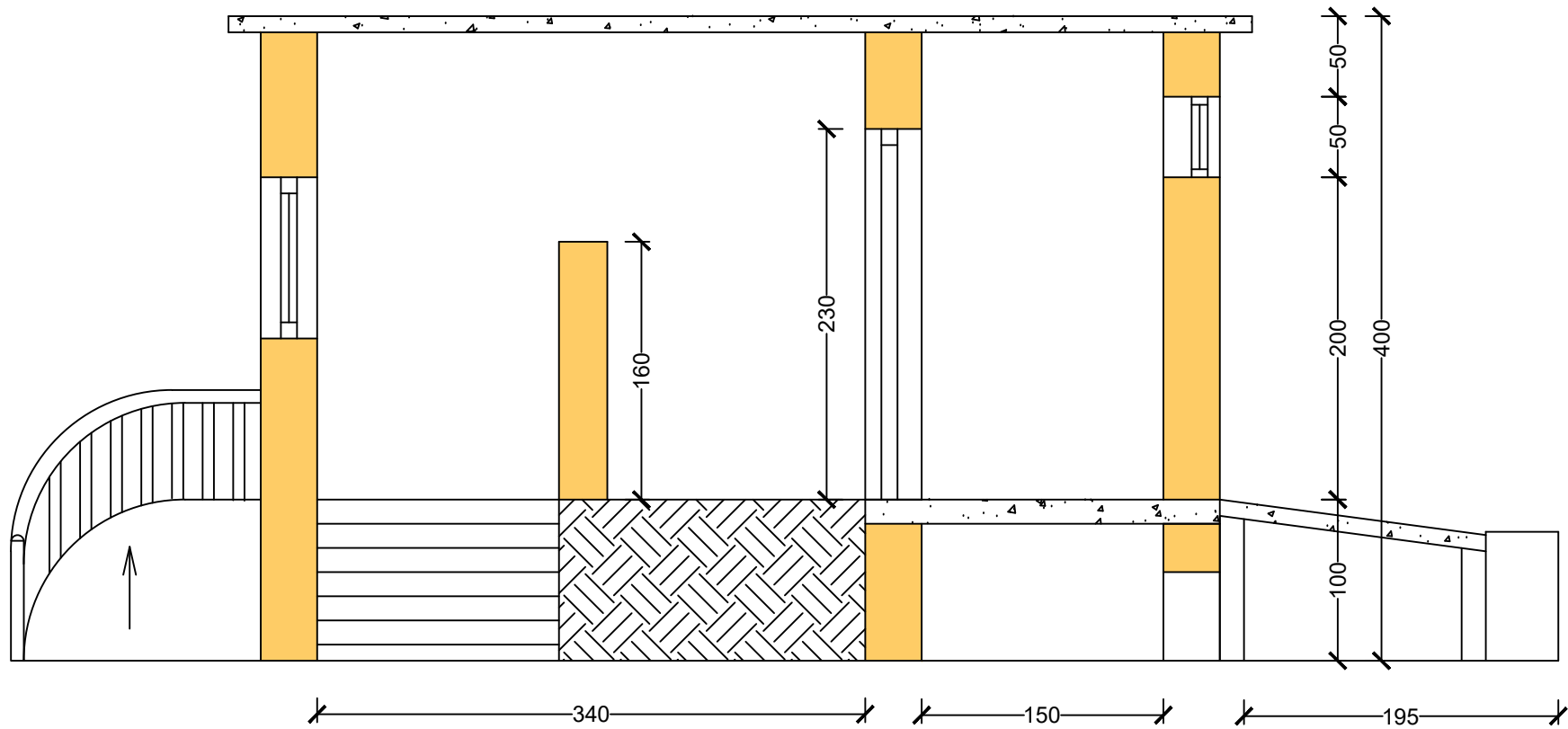

Cross Section (A-A)

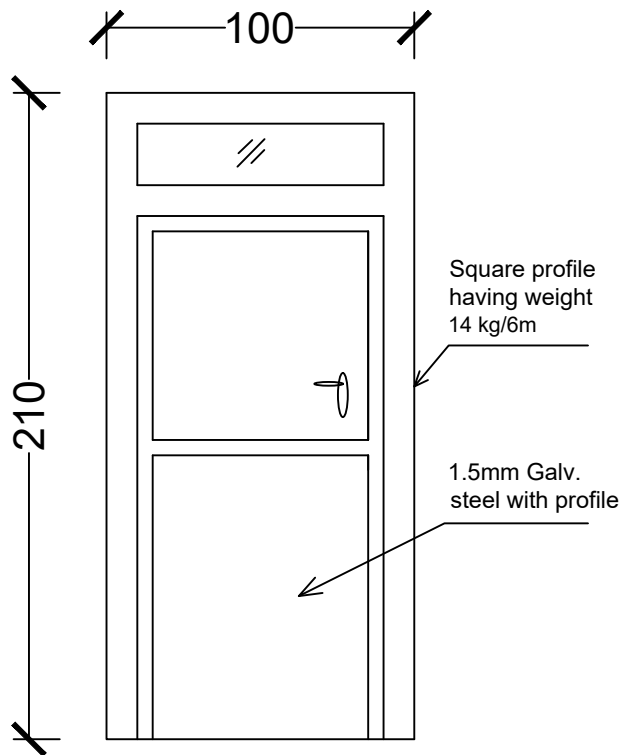

Door Specification

Doors are different from school to school in size and materials based on the BOQ.

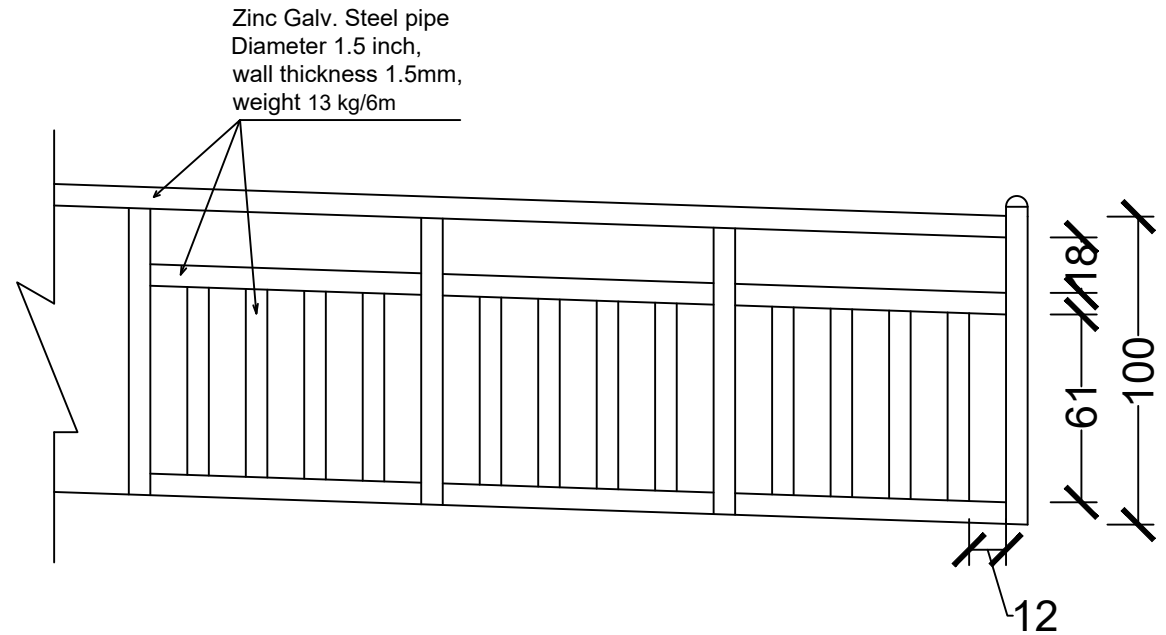

Hand Rail Drawing

Note:

All dimensions are in cm unless otherwise stated.

All pipes diameter is 1.5 inch with wall thickness 1.5mm & weight 13kg/6m Pipe.

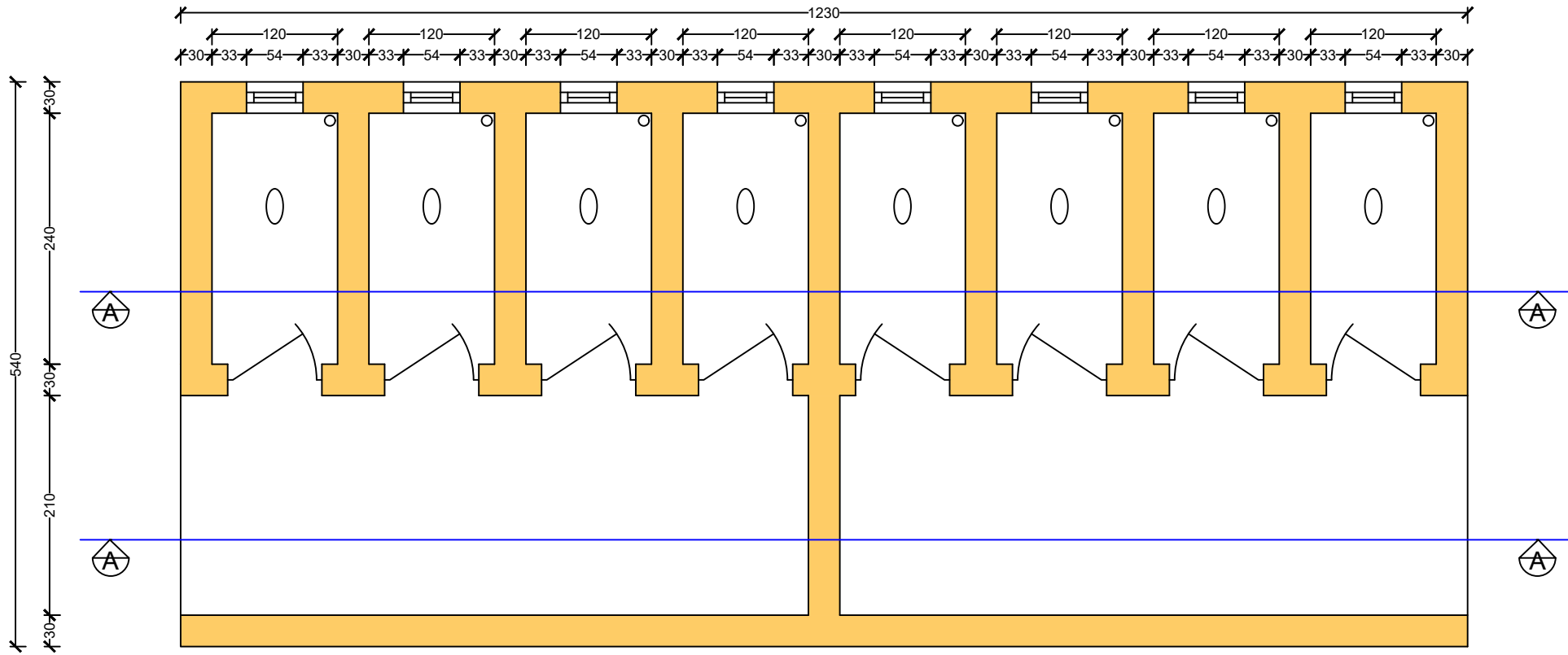

Latrine Block Plan

The latrine drawing is not representing all schools latrine block that will be rehabilitated and improved, Latrine blocks differ from school to school. The Contractor should check each Latrine Block before filling of the BOQ.

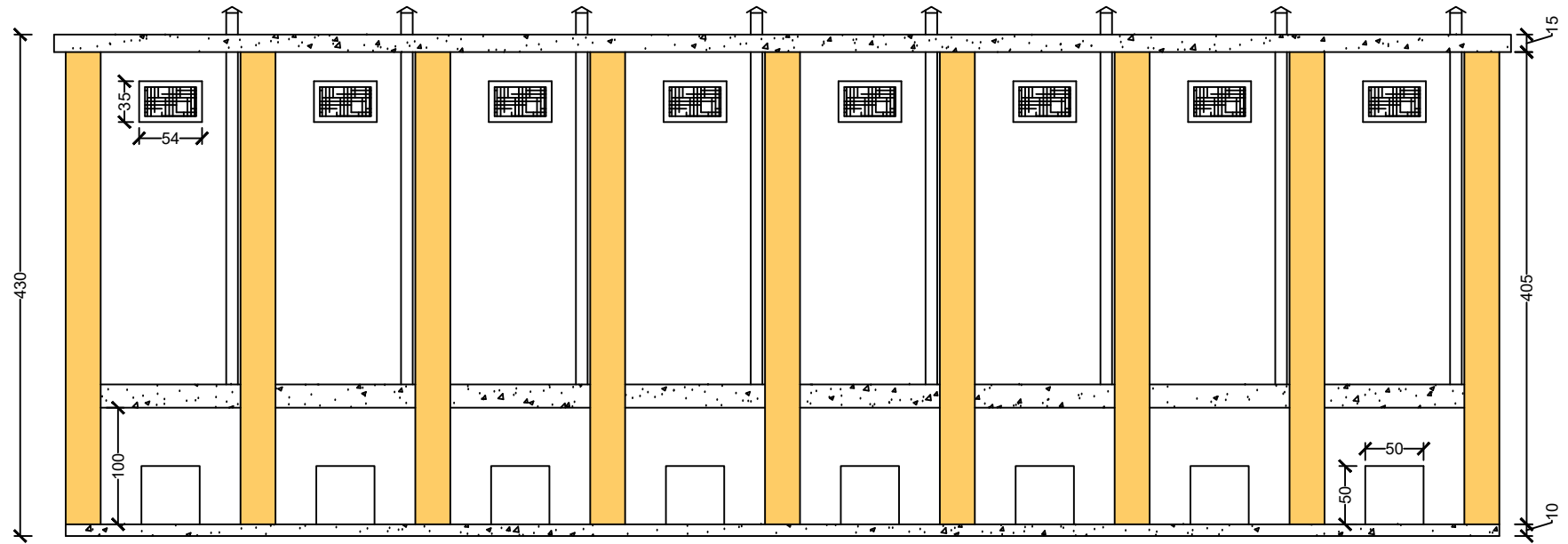

section (B-B)

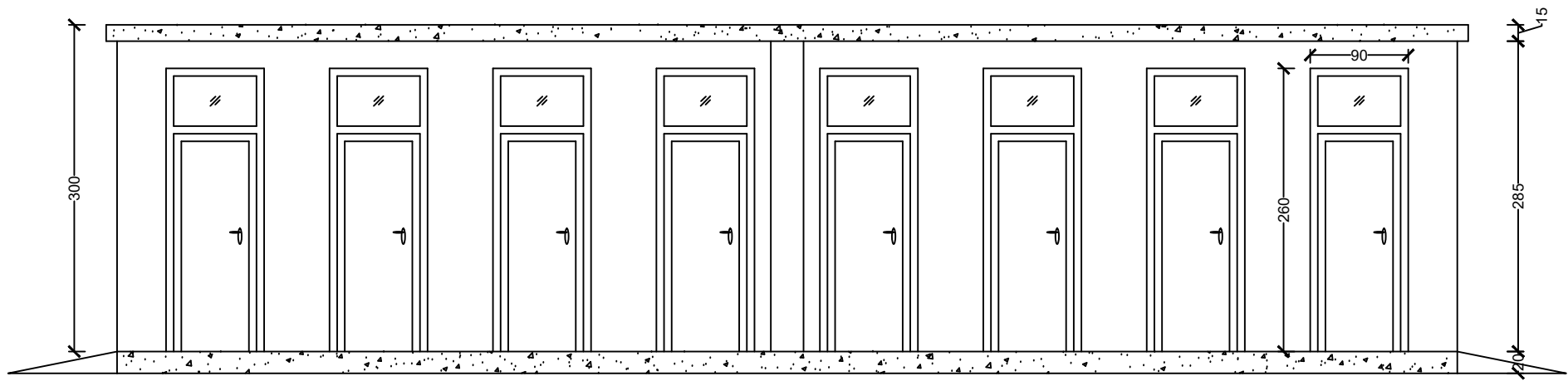

Section (A-A)

Beam and Slab Reinforcement Details

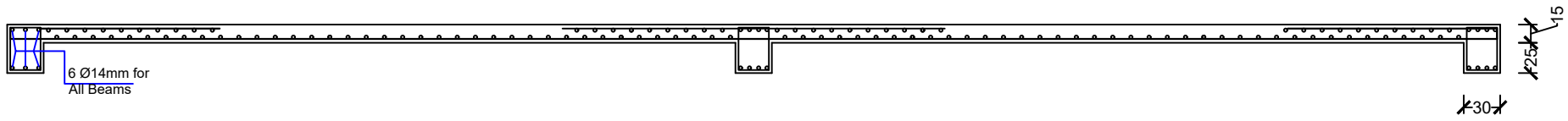
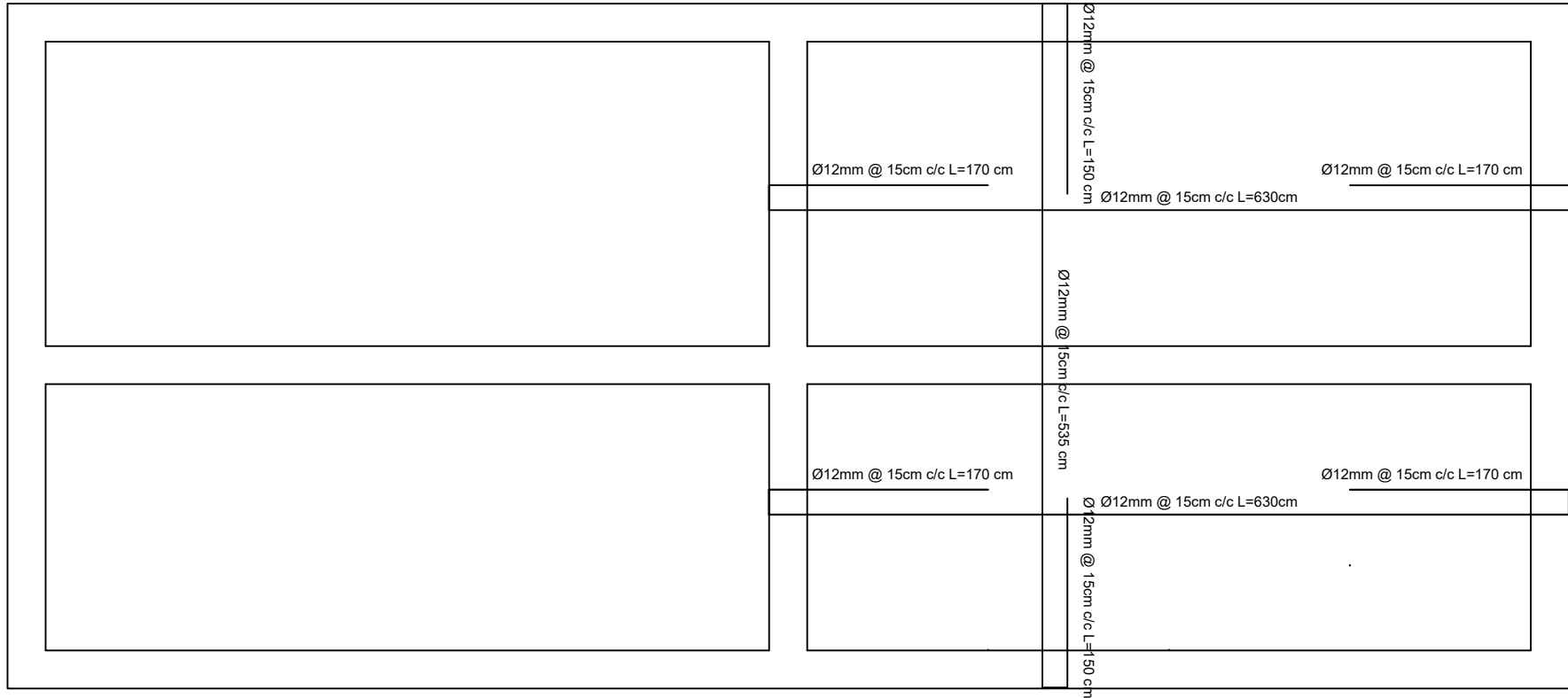

Septic Tank Drawing

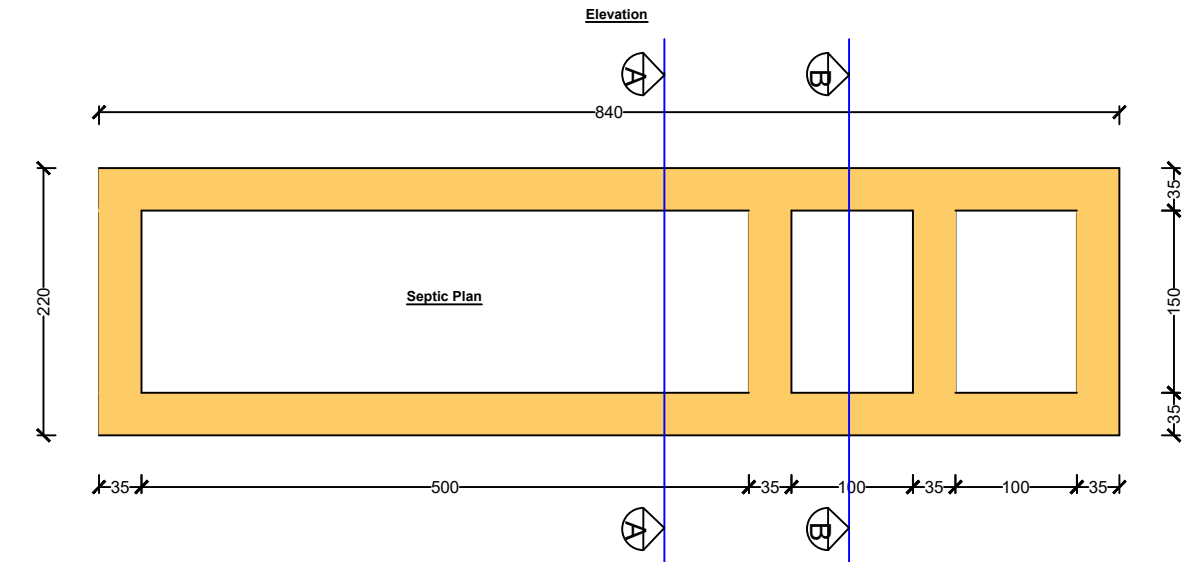
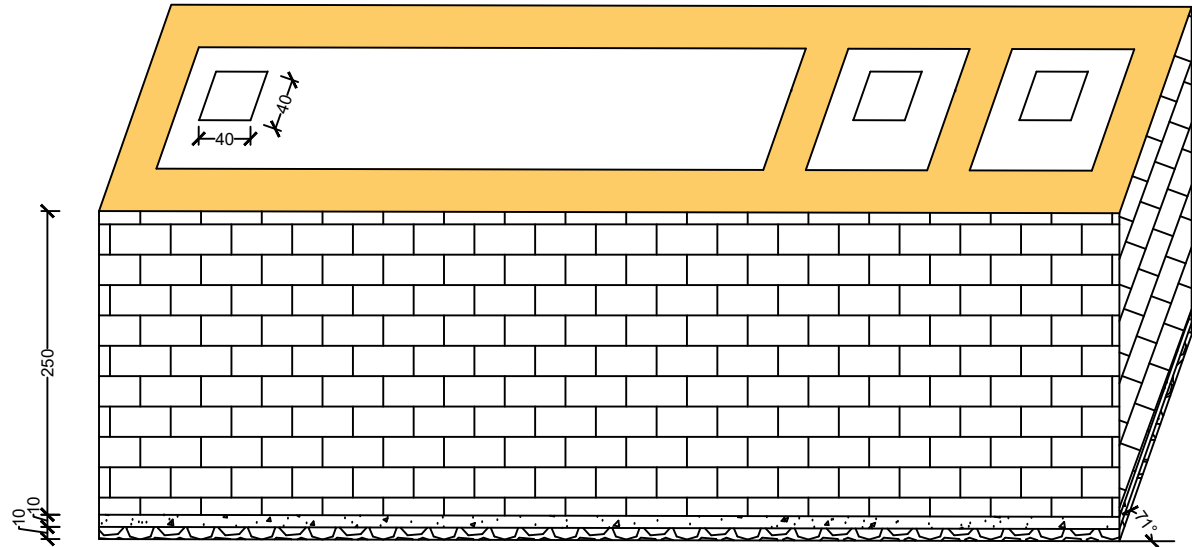
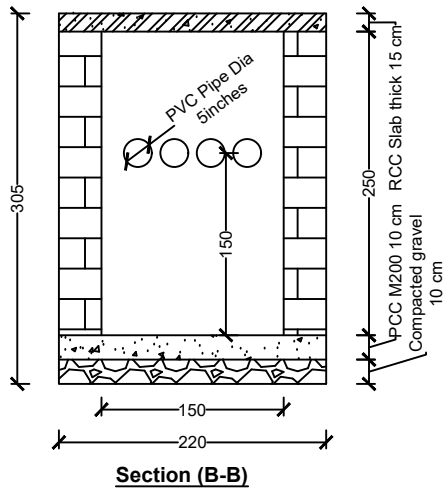
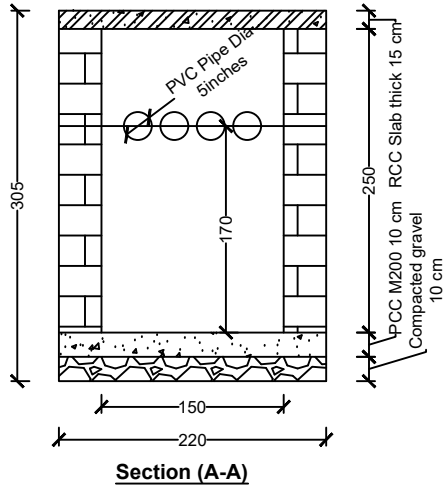

Drawing for Hand Washing Station:

Not on scale

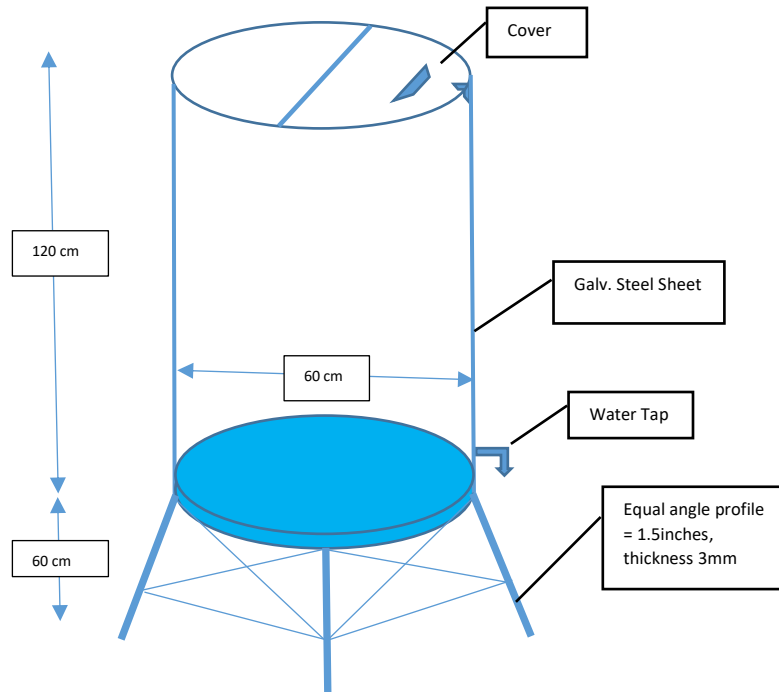

Specifications for Hand Washing Station

No	Description	Aprox. Capacity (Liters)
1	Water Container for hand washing Made of Galv. Steel Sheet, thickness 19 Gauge or 1.1mm with fixed stand made of double sized equal Angle 1.5 inches, Size shown in the drawing.	300
2	20 Liter Bucket made of Glv. Steel sheet best quality	20

