

Main Office

Golayee Wazirabad
PO Box 208
Kabul, Afghanistan
Phone: +93 202230752
Mobile: +93 700288232
E-mail: dacaar@dacaar.org
Website: www.dacaar.org

REQUEST FOR QUOTATION**Construction Work of Farmer Gathering Centre and Septic Tank in Faryab Province**

دفتر مرکزی
گولایی وزیرآباد
پست بکس ۲۰۸
کابل، افغانستان
تلفون: +۹۳۲۰۲۲۳۰۷۵۲
موبایل: +۹۳۷۰۰۲۸۸۲۳۲
ایمیل: dacaar@dacaar.org
وبسایت: www.dacaar.org

DACAAR RFQ 45 PRF-423 NMFA/1805-NMFA/RNF1.11/FRY-1809/FRY-1802/05.2020**Date: June 01, 2020**

DACAAR invites experienced interested individuals & companies for the construction work of Two Farmer Gathering Centre Building and Septic Tank in Dawlat Abad and Pashtoon Kot Districts of Faryab Province.

داکار به اعمار ساختمان دو باب مرکز اجتماع دهقانان و چاه فاضل آب آن در ولسوالی های دولت آباد و پشتون کوت ولایت فاریاب ضرورت دارد، و از تمام علاقمندان واجد شرایط تقاضا بعمل میآورد تا آفر های سربسته شانرا قبل از معیاد تعیین شده به دفتر داکار بسپارند.

Sealed offers must reach to DACAAR Main Office Logistics Unit located in (Street No. 12, Taimani Project, Qala-e-Fathullah, Kabul Province) till 4:00pm June 12, 2020.

آفرها باید الی تاریخ 12 جون 2020 ساعت 4:00 عصر به شعبه لوجستیک دفتر مرکزی داکار واقع (پروژه تایمینی پایکوب نصور سرک 12 قلعه فتح الله ولایت کابل) سپرده شود.

The bid opening session will be held on June 15, 2020 at 10:30am in DACAAR Main Office, Kabul Province and the winner of the bidding will be notified shortly after the bid opening session.

مجلس آفرگشایی ساعت 10:30 قبل از ظهر تاریخ 15 جون 2020 در دفتر مرکزی داکار در ولایت کابل صورت میگیرد که متعاقباً برنده داوطلبی در اسرع وقت اطلاع خواهد یافت.

The interested companies/vendors can visit DACAAR Regional Office in Faryab Province for any technical issues or site visit before the closing date or contact the following contact numbers;

کمپنی های علاقمند میتوانند بخاطر مشاهده موقعیت ساحه پروژه ویا هم بخاطر موضوعات تخنیکي قبل از تاریخ معینه دفتر ساحوی داکار واقع ولایت فاریاب را ملاقات نمایند. شماره ارتباط و ایمل آدرس دفتر ساحوی داکار واقع ولایت فاریاب قرار ذیل است:

Phone No: +93 (0) 797 011 010

Email: northwest.rm@dacaar.org

شماره تماس: +93 (0) 797 011 010

ایمل آدرس: northwest.rm@dacaar.org

Please use Annex (III) for Technical Specification and Drawings, Annex (II) for Work Plan and Annex (I) for Financial purposes.

لطفاً ضمیمه (I) را بخاطر ارایه آفر، ضمیمه (II) را بخاطر پلان کاری و ضمیمه (III) را بخاطر مشخصات تخنیکي مشاهده نمائید.

Terms and Conditions**شرایط قرارداد**

- Contractor should accomplish Construction of Two Farmer Gathering Centre Building and Septic Tank are in Dawlatabad and Pashtoon Kot Districts of Faryab Province and hand over to DACAAR in complete manner.
- The mentioned construction work of Two Farmer Gathering Centre Building and Septic Tank should be completed as soon as possible, In case you cannot complete the contract during the mentioned period, please write down your own time period for completion of task.
- Payment will be carried out within 15 working days after inspection and complete delivery.
- Quotations should be valid for 60 days and quotations without sign, thumb and signature will not be accepted.

- قراردادی مکلف است کار اعمار ساختمان دو باب مرکز اجتماع دهقانان و چاه فاضل آب آن در ولسوالی های دولت آباد و پشتون کوت ولایت فاریاب به صورت مکمل اعمار نموده و تسلیم داکار نماید.
- کار اعمار دو باب ساختمان مرکز اجتماع دهقانان و چاه فاضل آب آن باید هر چه عاجل به پایه اكمال برسد، و اگر شما در مورد زمان بندی آن مشکل داشته باشید، میتوانید مدت زمان واقعی که شما امکان تکمیل کار را داشته باشید در آفر تان بنوسید.
- پرداخت پول بعد از تصدیق بخش تخنیکي و تحویل دهی که در مشخصات کاری ذکر گردیده مکمل الی 15 روز کاری میباشد.
- قیمت داده شده باید به مدت 60 روز مدار اعتبار باشد و قیمت های بدون مهر، شصت و امضا مورد قبول نمیباشد.

5. The winner of the tender must deposit 10% amount of total contract to DACAAR bank account as contract Performance Guarantee before signing the contract and the mentioned amount is refundable after successful completion of the project.
5. برنده داوطلبی مکلف است تا 10% مجموع ارزش قرارداد را بشکل تضمین بانکی از اجرای کامل و موفقانه قرارداد قبل از امضای آن به حساب بانکی داکار بپردازد. مبلغ متذکره در صورت اجرا موفقانه قرارداد قابل باز پرداخت میباشد.
6. In case of delay in construction work without any logical reasons, 0.5% of total value of the incomplete construction work will be deducted from the payment. This penalty will be charged for each official day of delay.
6. در صورت تأخیر در ختم قرارداد بدون عذر موجه در وقت معینه آن، مبلغ 0.5% از هر روز کار تأخیر شده بطور جرمانه از مجموع ارزش قرارداد اخذ میگردد.
7. Prices shall be given in Afghanis (AFN) including all duties, materials, transport, loading, unloading, and other activities costs. Offers without sign and stamp will not be accepted.
7. قیمت ها به افغانی داده شود و باید شامل تکس، انتقال، قیمت مواد، بارگیری، تخلیه و غیره فعالیت ها میباشد. آفر بدون مهر و امضا مورد قبول نمیشود.
8. The contractor should guarantee damage of Building and Septic Tank for One Year, if it breaks down or damages then the contractor is responsible to repair/solve the problem without any compensation paid.
8. قرارداد کننده از عدم خرابی و چپه شدن ساختمان و چاه فاضل آب برای مدت یکسال ضمانت نماید و در صورت وقوع همچو حالات قراردادی مکلف است تا بدون پرداخت هزینه آنرا دوباره ترمیم نماید.
9. DACAAR's technical team (Site Engineer) will check all the specifications of Building and Septic Tank. If it is not according to the DACAAR specifications, DACAAR Technical Team has reserved the right to reject the construction and installation.
9. هیئت تفتیش و بررسی داکار تمام مشخصات ساختمان و چاه فاضل آب آن را مطابق قرارداد چک و ملاحظه نموده در صورتیکه مطابق مشخصات قرارداد نباشد، داکار حق دارد تا آنرا مسترد نماید.
10. 2% Tax will be applicable on the companies that has related valid business license and 7% Tax will be applicable on the companies that have invalid business license, or on individuals who do not have business license, will be deducted from the contractor as a withholding tax and DACAAR will pay that amount to Ministry of Finance, the amount starts from (1 AFN). Please attach copy of your license with your offers.
10. 2% مالیه برای شرکت هائیکه دارای جواز مربوط با اعتبار میباشد، و 7% مالیه برای شرکت هائیکه دارای جواز بی اعتبار میباشد، و یا اشخاصیکه جواز ندارند توسط داکار وضع گردیده و به وزارت مالیه دولت اسلامی افغانستان پرداخت میشود، آغاز مبلغ مالیه از (1 افغانی) میباشد.
11. All Transportation of construction tools including Water, Mason and Labourers Costs will be the responsibilities of contractor and the contractor must hand over the project based on specifications specified in Annex I, II and III.
11. انتقال هرگونه لوازم ساختمانی بشمول آب و کاریگران فنی و غیر فنی به عهده قراردادی میباشد و پروسه تسلیمی پروژه کاملاً به اساس مشخصات داده شده در ضمایم I, II, III ذکر گردیده است میباشد.
- Note:** All Construction Materials without water will be provided by DACAAR and the bidders must not include the construction materials costs to their offer.
- نوٹ:** تمام مواد ساختمانی بدون آب توسط داکار تهیه میگردد، و داوطلبان باید قیمت مواد ساختمانی را در آفر خود شامل نسازند.
12. DACAAR does not accept sub-contract, in case if it is found that the supplier has given the contract to sub-contracting supplier, the contract will automatically be terminated and the supplier will lose their performance guarantee and no compensation will be paid to the contractor.
12. داکار به هیچ عنوان قرارداد دست دو را نه پذیرفته، در صورت وقوع چنین حالت قرارداد بصورت اتومات فسخ و قراردادی پول تضمین و حق اجوره خویش را از دست میدهد.
13. DACAAR (Logistics Unit) adheres to National and International laws on child labour DACAAR makes sure all its suppliers and vendor abide by such laws preventing child labour in all DACAAR activities countrywide.
13. دفتر داکار (شعبه لوژیستیک) با در نظر داشت قوانین ملی و بین المللی برای جلوگیری از کار کودکان مصمم بوده و سعی میکند که تمام فعالیتهای تهیه کننده گان و مشتریان این اداره به این اصل پایند باشند.

14. The Humanitarian Organizations (HO) may conduct onsite visit in the contractor's premises (or may take similar measures) to ensure compliance.
14. سازمان های بشر دوستانه (HO) ممکن است تا از محلات و سایت ها به بخاطر اطمینان خاطر و تطبیق درست کار توسط قرار داد گیرنده بازدید بعمل آورده و یا ممکن است اقدامات مشابه را انجام دهد.
15. Award of the contract will be based on the experience, machinery, price, capacity & potentiality of bidder which will be decided after the technical evaluation of the company. It is the right of DACAAR to make the decision of awarding contract.
15. برنده شدن قرارداد نظر به تجربه کاری، ماشین آلات، قیمت، توانائی و ظرفیت کاری داوطلب بوده و بعد از بررسی کمپنی صورت خواهد گرفت. البته داکار تنها حق تصمیم گیری در این زمینه را دارا میباشد.

For more details, please visit DACAAR Logistics Unit Main Office Kabul, Sunday through Thursday, from 8:00am to 03:00 PM or contact on below Email Addresses:

jamal@dacaar.org or faizullah@dacaar.org

Yours Sincerely,

Manager - Logistics

Date: June 01, 2020



ANNEX (I)
Budget Breakdown/ فورم ارايه آفر
DACAAR RFQ 45 PRF-423 NMFA/1805-NMFA/RNF1.11/FRY-1809/FRY-1802/05.2020

Lot I: Construction Work of Farmer Gathering Centre Building and Septic Tank Dawlatabad District of Faryab Province

S/No	Item	Specifications	Unit	Quantity	Unit Price including 2/7% Government Tax (AFN)	Total Price including 2/7% Government Tax (AFN)
1.	Construction Work of One Farmer Gathering Center (FGC) building (Labor wages only)	Based on drawing mentioned in Annex (III)	M ²	213		
2.	Construction Work of One Septic Tank (Labor wages only)	Based on drawing mentioned in Annex (III)	M ²	13.40		
Total Cost: AFN						

Tendered Name: _____ اسم آفر دهنده:

Address & Stamp: _____ آدرس و مهر کمپنی

Mobile No.: _____ نمبر موبائیل

Email _____ ایمل آدرس

Time required for completion of Construction Work _____ مدت نیاز برای تکمیل کار ساختمان

ANNEX (I)
Budget Breakdown/ فورم ارايه آفر
DACAAR RFQ 45 PRF-423 NMFA/1805-NMFA/RNF1.11/FRY-1809/FRY-1802/05.2020

Lot II: Construction Work of Farmer Gathering Centre Building and Septic Tank Pashtoon Kot District of Faryab Province

S/No	Item	Specifications	Unit	Quantity	Unit Price including 2/7% Government Tax (AFN)	Total Price including 2/7% Government Tax (AFN)
1.	Construction Work of One Farmer Gathering Center (FGC) building (Construction Work Only)	Based on drawing mentioned in Annex (III)	M ²	213		
2.	Construction Work of One Septic Tank (Construction Work Only)	Based on drawing mentioned in Annex (III)	M ²	13.40		
Total Cost: AFN						

Tendered Name: _____ اسم آفر دهنده:

Address & Stamp: _____ آدرس و مهر کمپنی

Mobile No: _____ نمبر موبائیل

Email _____ ایمل آدرس

Time required for completion of Construction Work _____ مدت نیاز برای تکمیل کار ساختمان

ANNEX (II)

Tentative Work Plan/ پلان کارى تخمينى

DACAAR RFQ 45 PRF-423 NMFA/1805-NMFA/RNF1.11/FRY-1809/FRY-1802/05.2020

Construction Work of Farmer Gathering Centre Building and Septic Tank Pashtoon Kot District of Faryab Province

S/N	Description	Location	Contract Start Date	Completion Date
1	Construction Work of One Farmer Gathering Center (FGC) building and Septic Tank (Construction Work Only)	Dawlatbad District of Faryab Province	June 21, 2020	October 30, 2020
2	Construction Work of One Farmer Gathering Center (FGC) building and Septic Tank (Construction Work Only)	Pashtoon Kot District of Faryab Province	June 21, 2020	October 30, 2020

ANNEX (III)

Work Specification and Drawings

DACAAR RFQ 45 PRF-423 NMFA/1805-NMFA/RNF1.11/FRY-1809/FRY-1802/05.2020

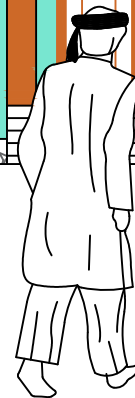
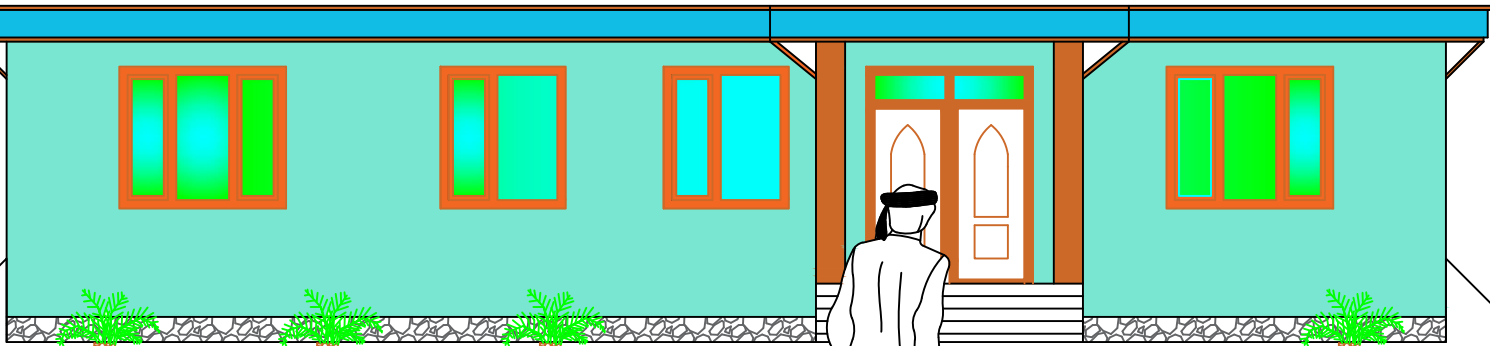
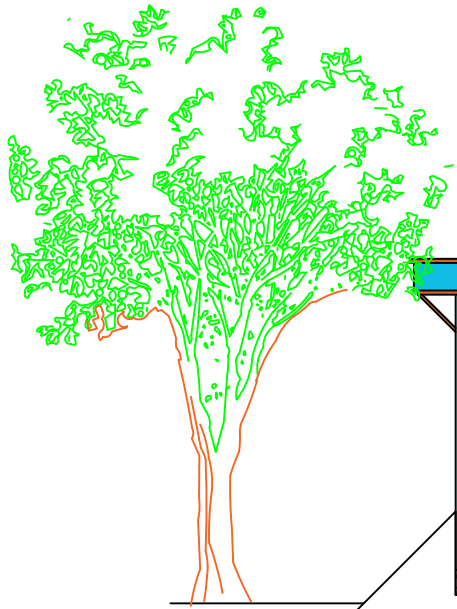

www.dacaar.org <small>Photo credit: www.dacaar.org</small>	Funded by	NMFA	Drawing	Eng. Ab.Malik & Eng.Na.jmuddin	Village	Any	All dimensions are in Cm	Date	<div style="border: 1px solid black; border-radius: 50%; width: 30px; height: 30px; display: flex; align-items: center; justify-content: center;"> 1 i2 </div>	Drawing Title
	Implemented by	DACAAR	Designed	Eng. Abdul Malik Yousufzal	District	Any		April.2020		Proposed FGC
			Checked by	Eng. Abdul Wali Muslih	Province	Faryab		Front View		

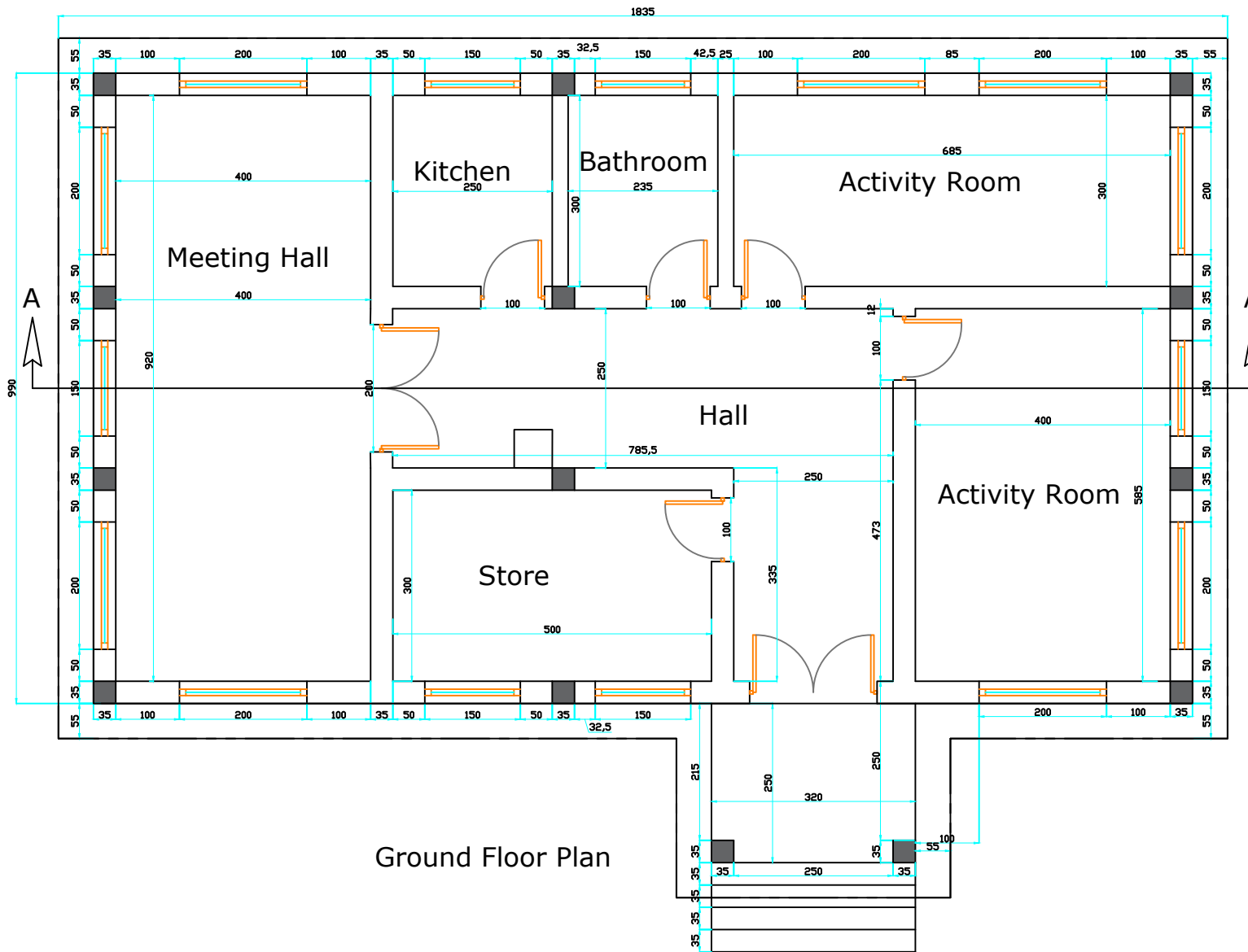

Ground Floor Plan

www.dacaar.org	Funded by	NMFA	Surveyed by	NWRD Field Engineer	Village	Any	All dimensions are in Cm	Date	2/12	Drawing Title Ground Plan of Farmer Gathering Center (FGC)
	Implemented by	DACAAR	Designed by	Eng. Abdul Malik Yosufzai	District	Any		April.2020		
			Checked by	Eng. Abdul Wali Muslih	Province	Faryab				

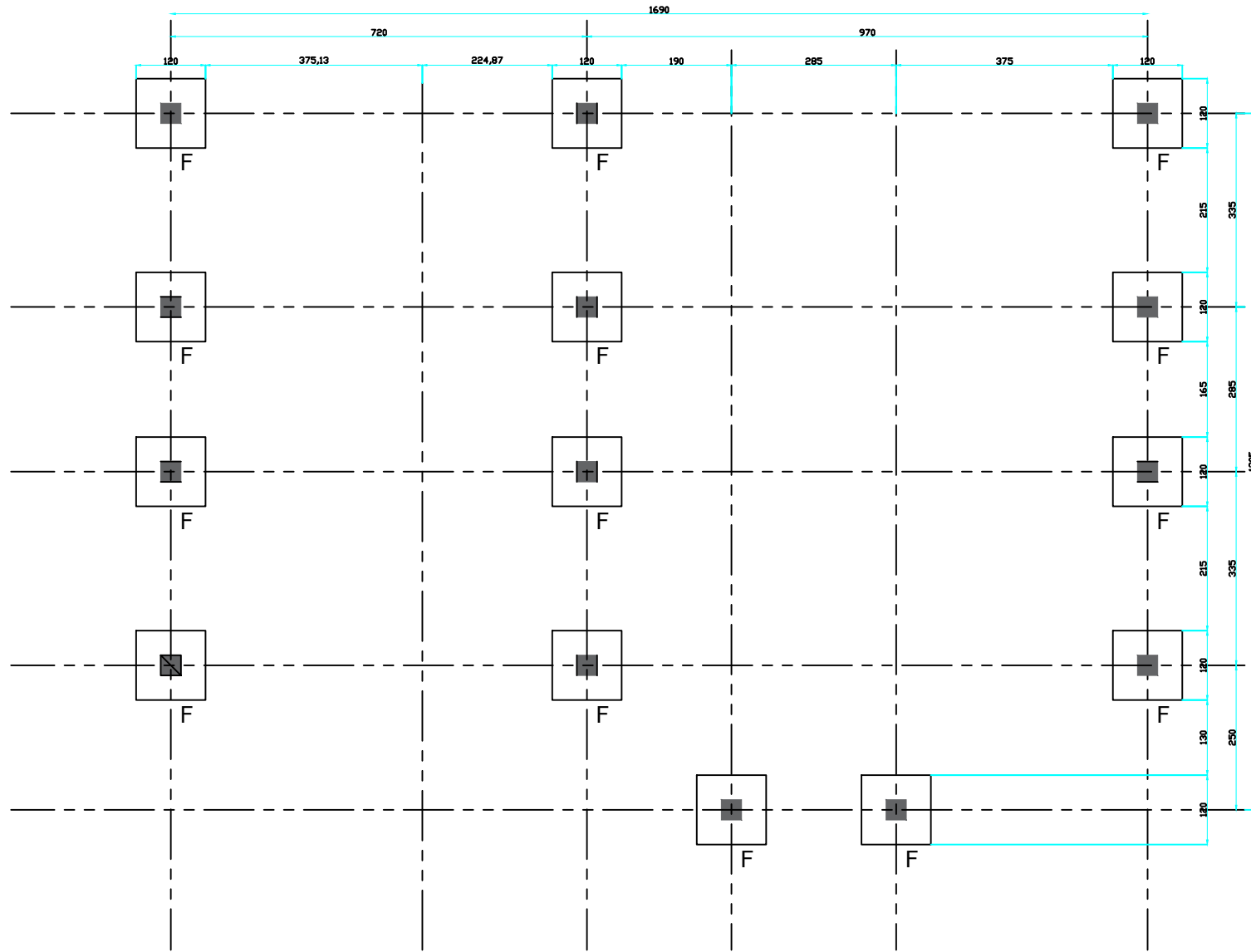

RCC Footing Plan

www.dacaar.org <small>Publications/Activity/Event/Activity Picture/Share Page Link</small>	Funded by	NMFA	Drawing		Village	Any	All dimensions are in Cm	Date	3 12 April, 2020	Drawing Title	FGC RCC Footing Plan
	Implemented by	DACAAR	Designed	Eng. Abdul Malik Yousufzal	District	Any					
			Checked by	Eng. Abdul Wali Muslih	Province	Faryab					

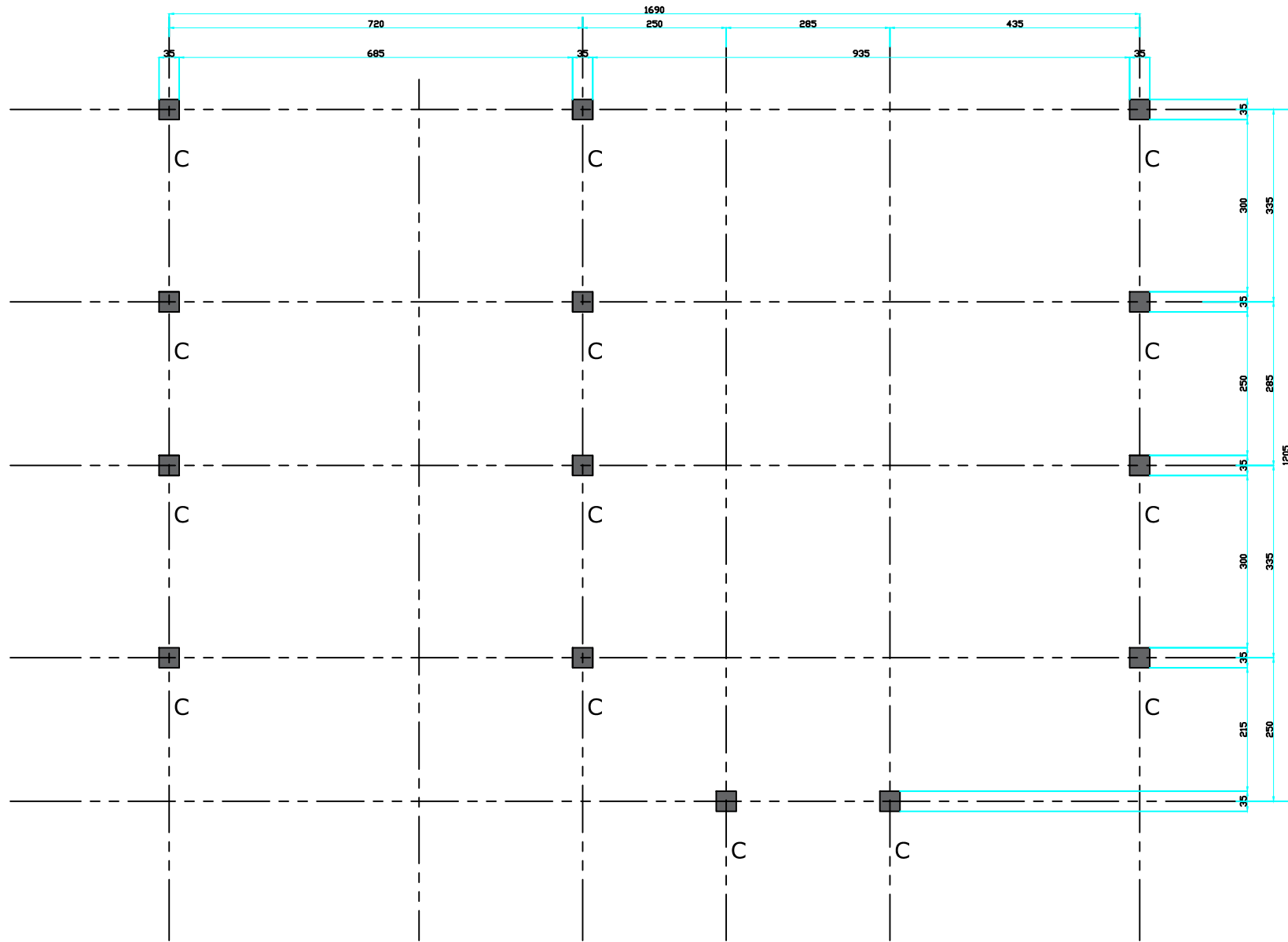

RCC Column Plan

www.dacaar.org	Funded by	NMFA	Surveyed	Eng. Ab.Malik & Eng.Na.jmuddin	Village	Any	All dimensions are in Cm	Date	4 12	Drawing Title
	Implemented by	DACAAR	Designed	Eng. Abdul Malik Yosufzal	District	Any		April.2020		RCC Column Plan
			Checked by	Eng. Abdul Wali Mustlih	Province	Faryab				

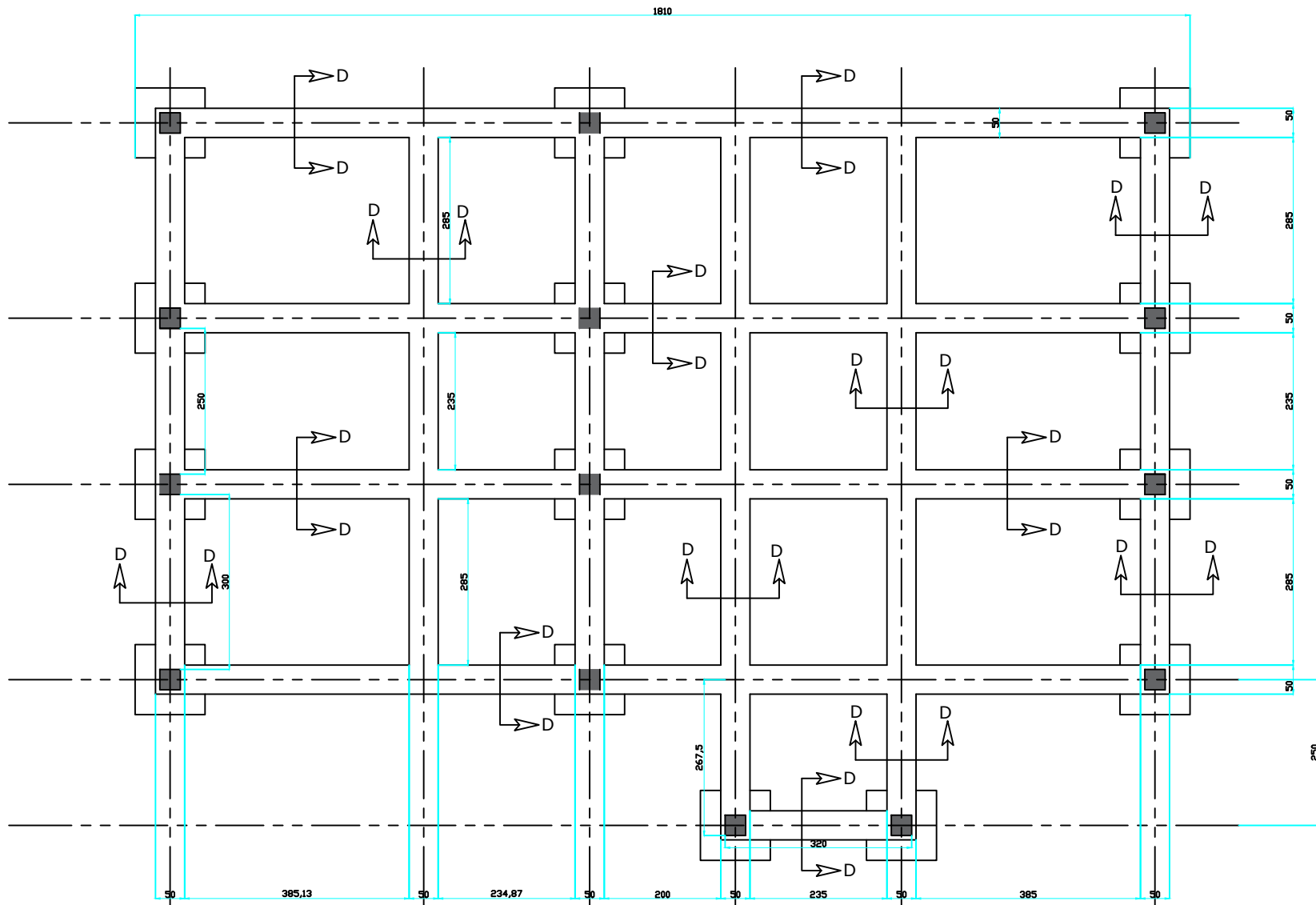

Stone Masonry Footing Plan

www.dacaar.org	Funded by	NMFA	Surveyed by	Eng. Ab.Malik & Eng.Na.jmuddin	Village	Any	All dimensions are in Cm	Date	5/12	Drawing Title
	Implemented by	DACAAR	Designed by	Eng. Abdul Malik Yosufzai	District	Any		April.2020		Stone Masonry Footing Plan
	Checked by	Eng. Abdul Wali Muslih	Province	Faryab						

Section B-B

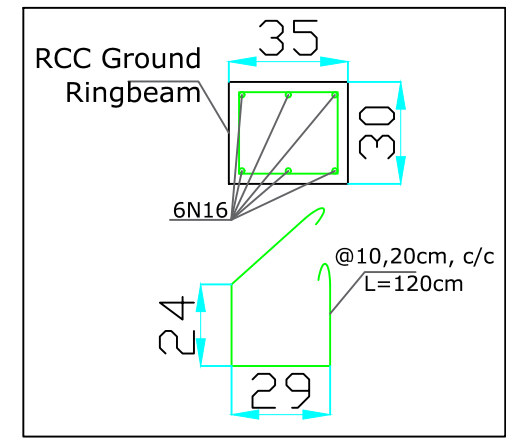
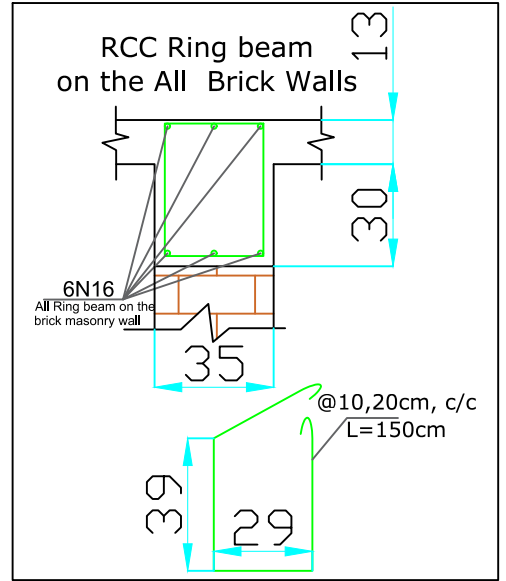
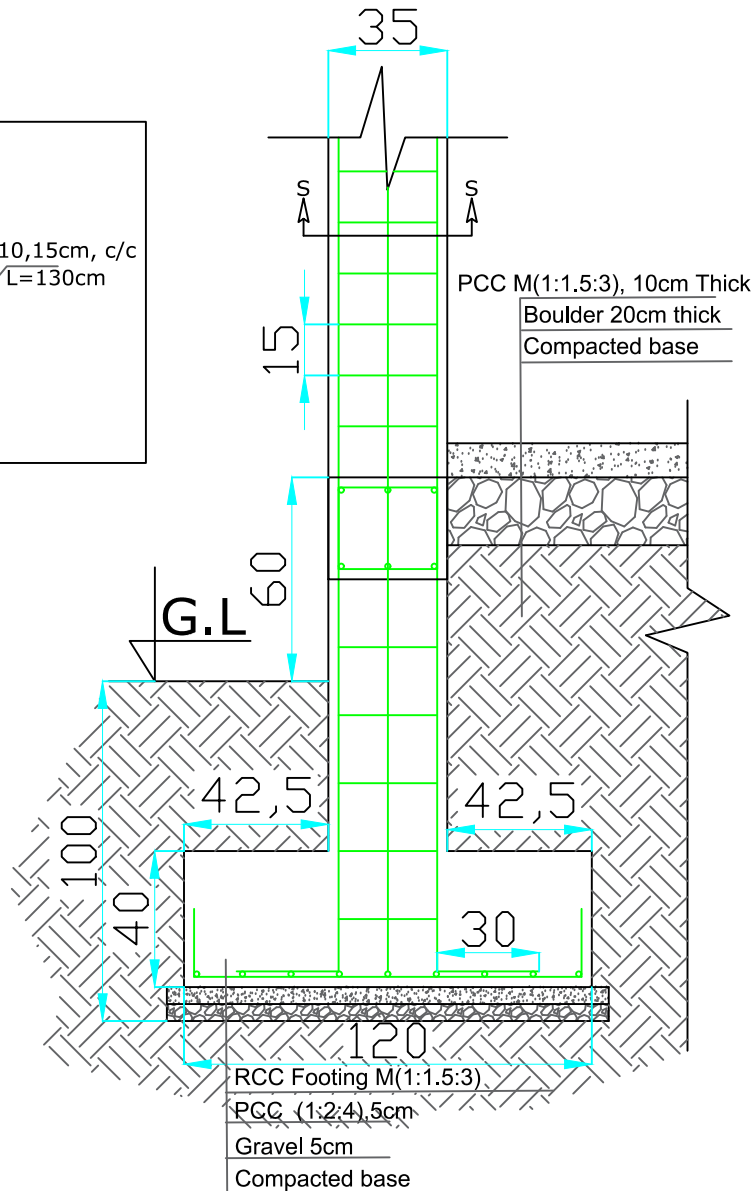
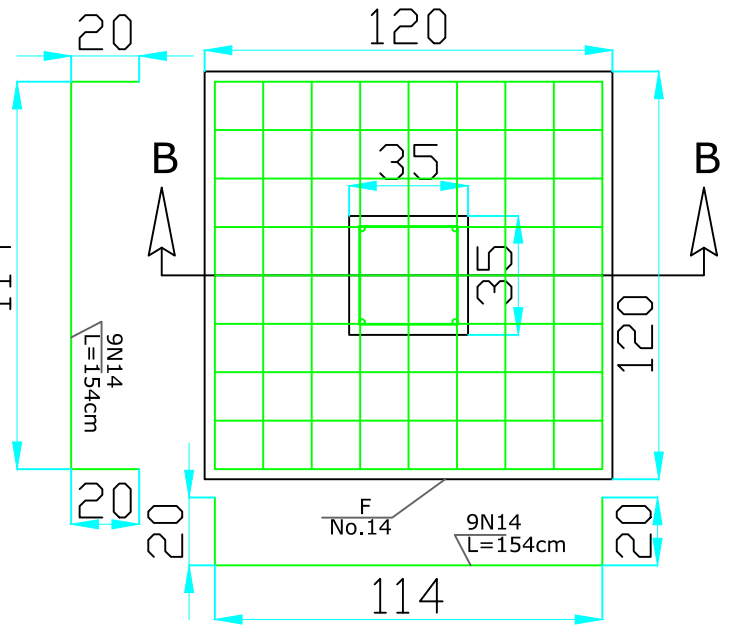
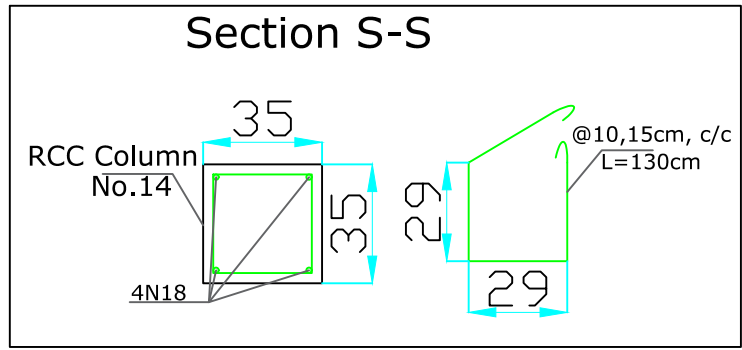

www.dacaar.org	Funded by	NMFA	Surveyed	Eng. Ab.Malik & Eng.Na.jmuddin	Village	Any	All dimensions are in Cm	Date	6 12	Drawing Title Section B-B Section S-S Ground Ring beam Top ring beam
	Implemented by	DACAAR	Designed	Eng. Abdul Malik Yosufzal	District	Any		April.2020		
	Checked by	Eng. Abdul Wali Mustlih	Province	Faryab						

Note:

1. All dimensions are in cm
2. concrete mix Ratio is (1:1.5:3)
3. Mark of deformed rebar not less than grade 60 Tashkent made in.
4. Use fresh cement and setrength not less than 10000PSi
5. Assume Safe bearing capacity of Soil not less than 1.5kg/cm²
6. All Forming mould should be steel plate and be very smooth and tight
7. For mixing of concrete must use mixer and during pouring concrete use vibrator
8. Before starting footing work Compaction of foundation is very necessary & density not less then 95%.
9. the Crashed stone,Sand & gravel must be clean from dust, soil and organic materials
10. Stone boulder should placed after compaction according to design or site condition.
11. PCC mix ratio is (1:2:4) and carry out in both all mentioned locations according to design.
12. Inside & out side plaster mix ratio (1:5)

Detail C

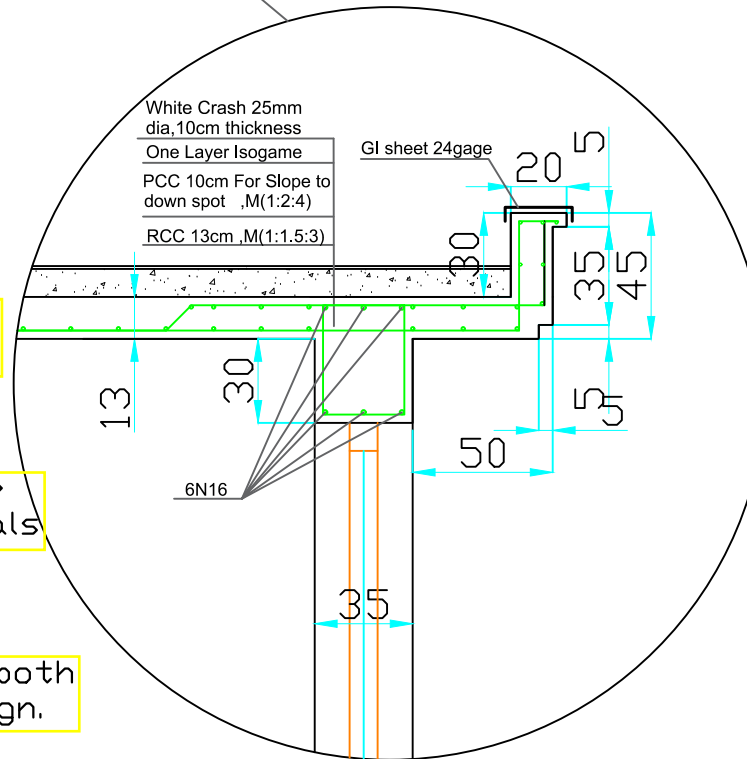

Section D-D

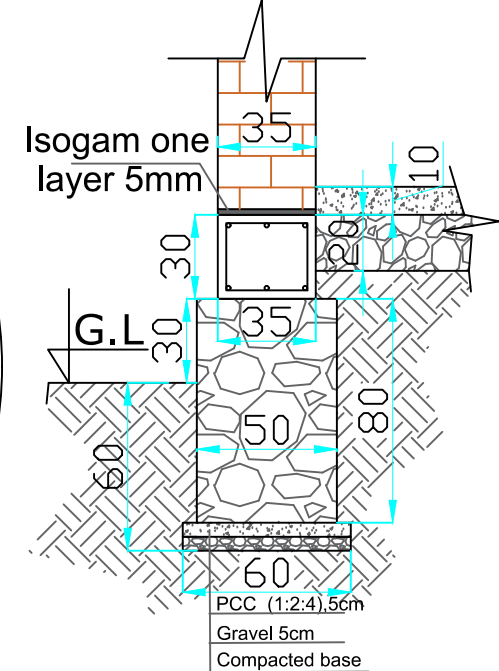

www.dacaar.org	Funded by	NMFA	Surveyed	Eng. Ab.Malik & Eng.Na.jmuddin	Village	Any	All dimensions are in Cm	Date	7/12	Drawing Title Detail C and Section D-D
	Implemented by	DACAAR	Designed	Eng. Abdul Malik Yosufzal	District	Any		April.2020		
			Checked by	Eng. Abdul Wali Mustlih	Province	Faryab				

Section A-A

White Crash 25mm
dia,10cm thickness
One Layer Isogame
PCC 10cm For Slope to
down spot ,M(1:2:4)
RCC 13cm ,M(1:1.5:3)

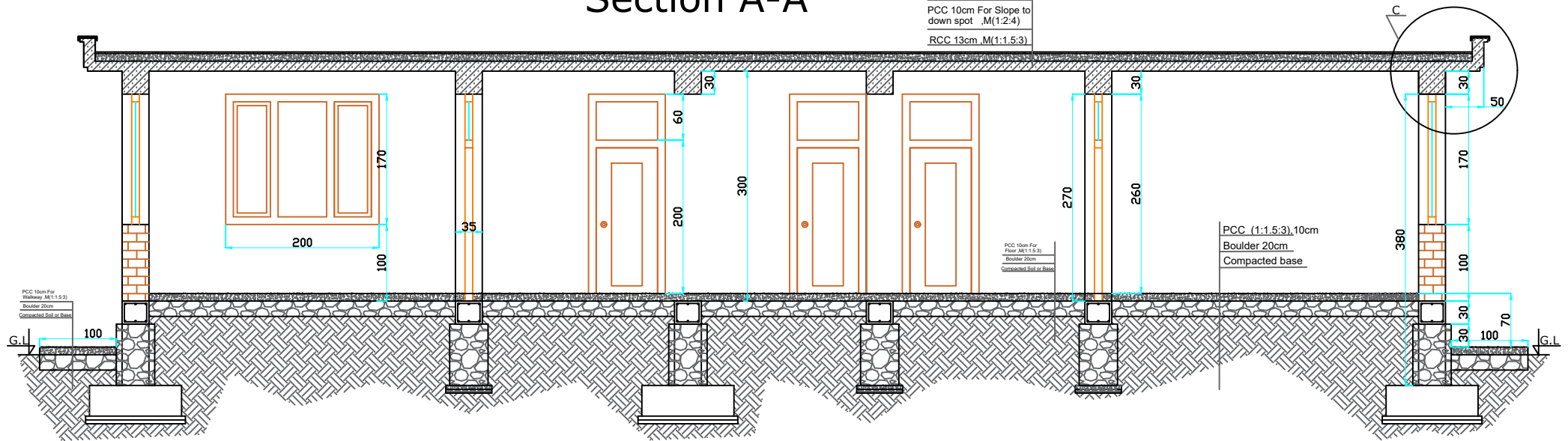

www.dacaar.org	Funded by	NMFA	Surveyed	Eng. Ab.Malik & Eng.Na.jmuddin	Village	Any	All dimensions are in Cm	Date	8 12	Drawing Title
	Implemented by	DACAAR	Designed	Eng. Abdul Malik Yosufzal	District	Any		April.2020		Section A-A
	Checked by	Eng. Abdul Wali Mustlih	Province	Faryab						

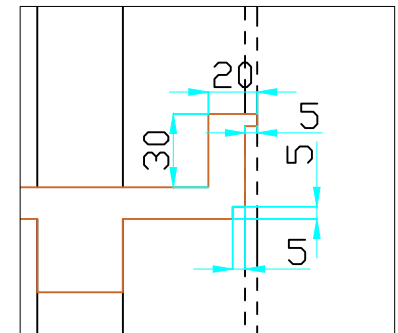
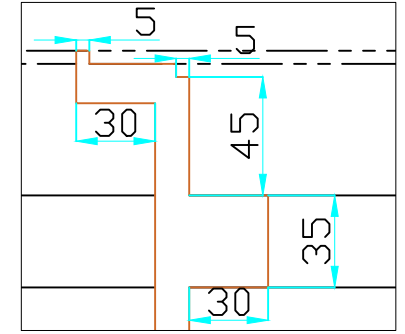
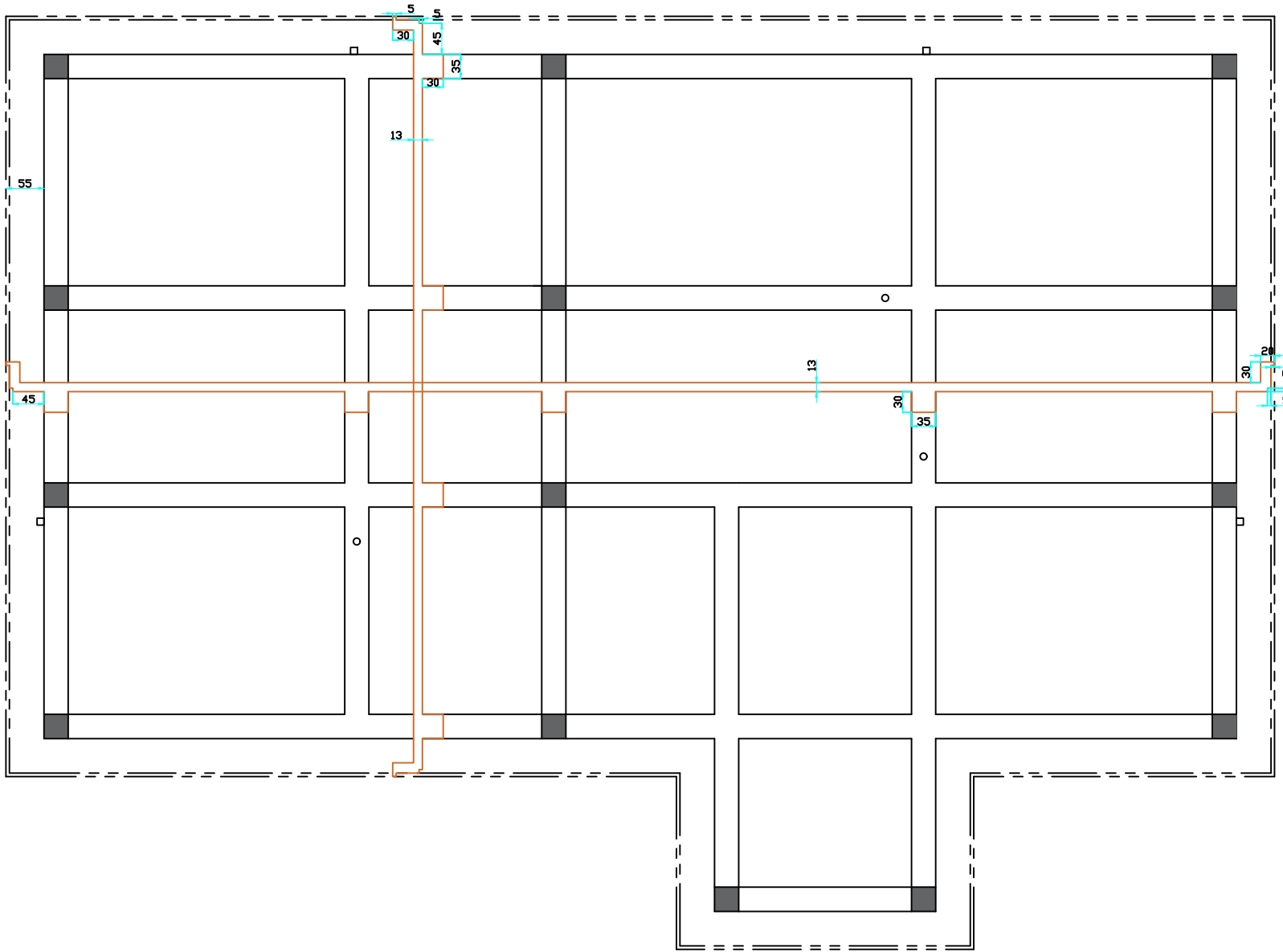

Forming plan of Roof Slab

www.dacaar.org	Funded by	NMFA	Surveyed	Eng. Ab.Malik & Eng.Na.jmuddin	Village	Any	All dimensions are in Cm	Date	9 12	Drawing Title
	Implemented by	DACAAR	Designed	Eng. Abdul Malik Yosufzal	District	Any		April.2020		Ceiling Forming plan
	Checked by	Eng. Abdul Wali Mustlih	Province	Faryab						

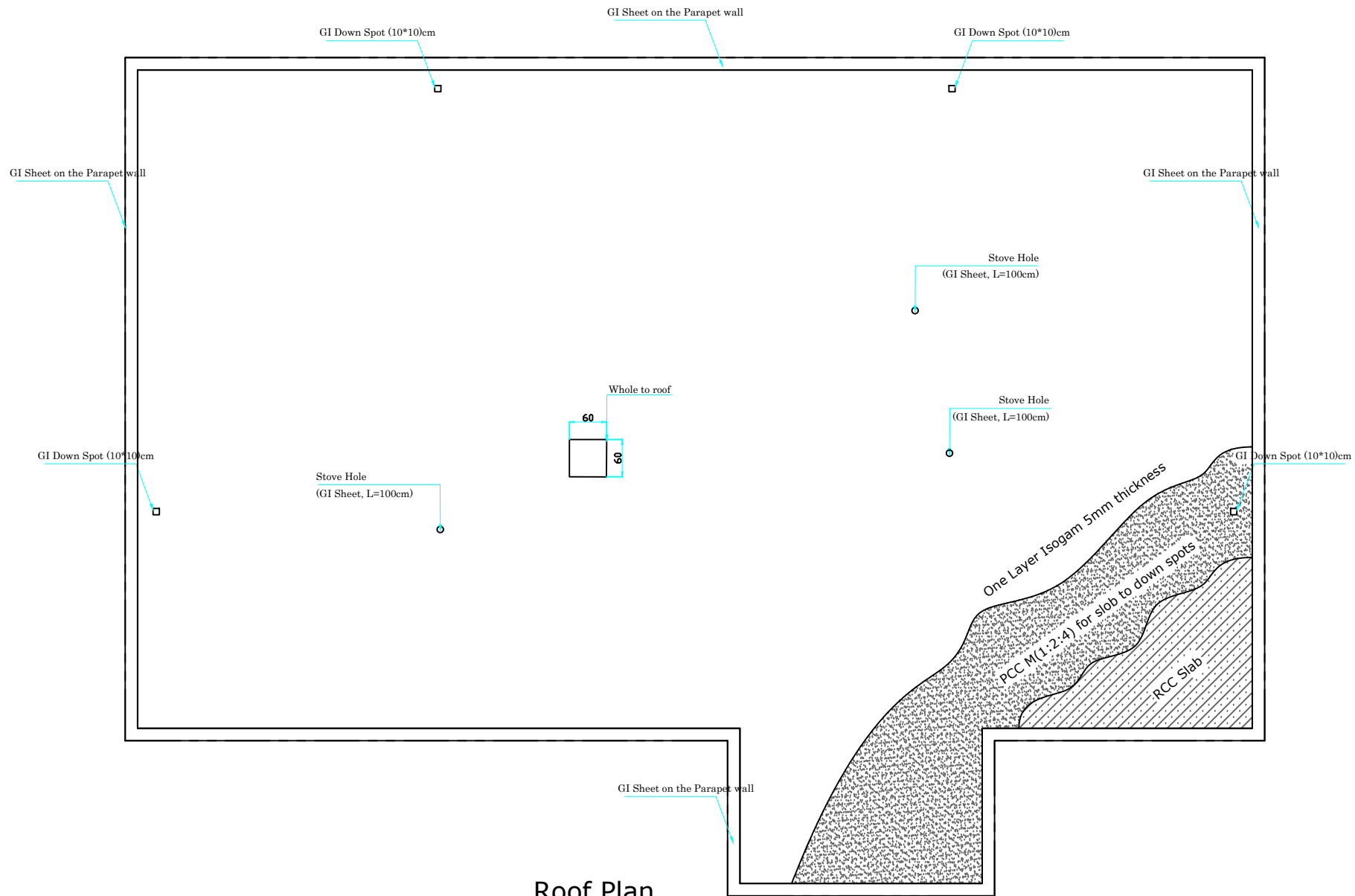

Roof Plan

www.dacaar.org	Funded by	NMFA	Surveyed	Eng. Ab.Malik & Eng.Na.jmuddin	Village	Any	All dimensions are in Cm	Date	10 12	Drawing Title
	Implemented by	DACAAR	Designed	Eng. Abdul Malik Yosufzal	District	Any		April.2020		Roof Plan
			Checked by	Eng. Abdul Wali Mustlih	Province	Faryab				

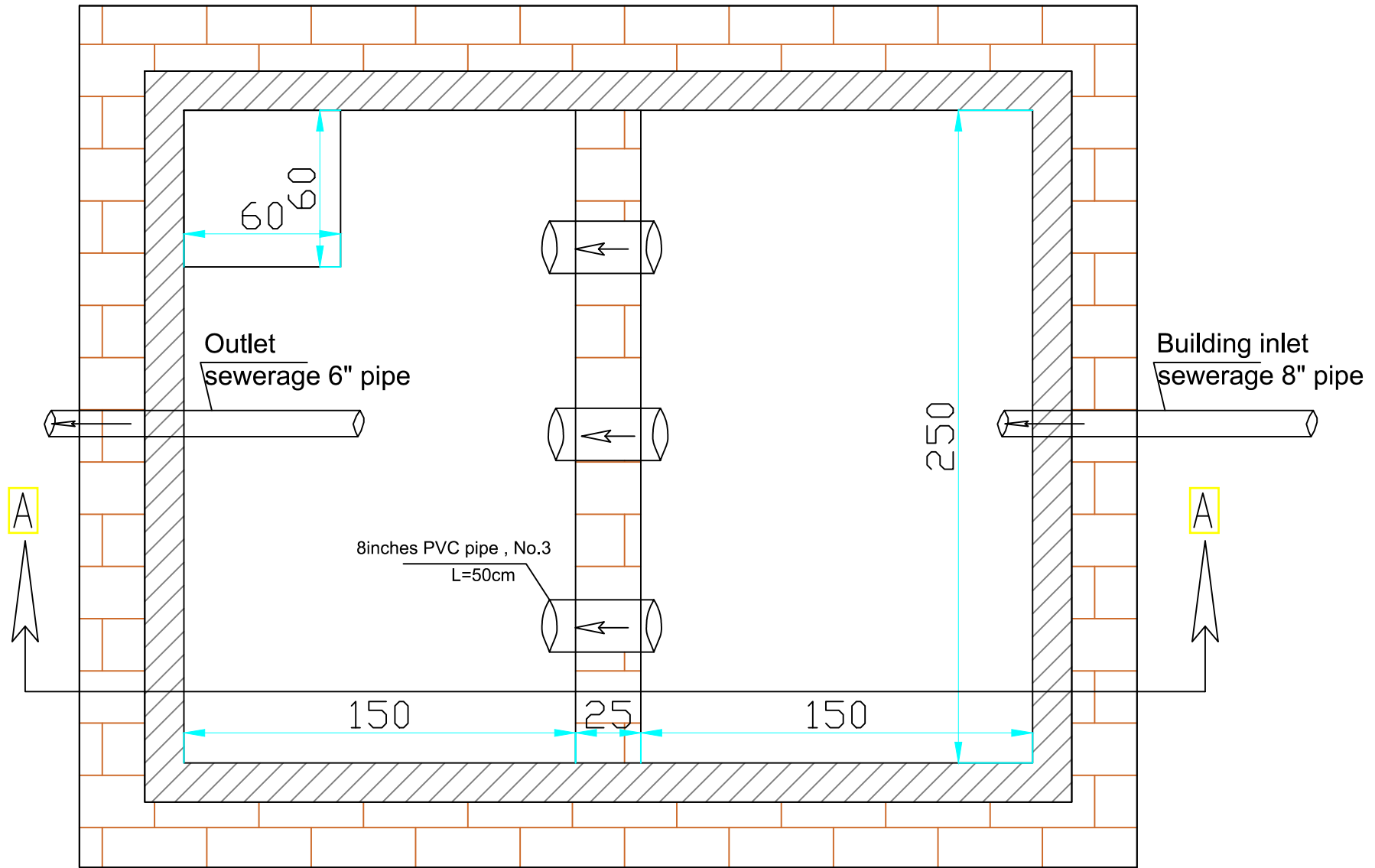

Septic Tank Plan

www.dacaar.org	Funded by	NMFA	Surveyed	Eng. Ab.Malik & Eng.Na.jmuddin	Village	Any	All dimensions are in Cm	Date	11 12	Drawing Title
	Implemented by	DACAAR	Designed	Eng. Abdul Malik Yosufzal	District	Any		April.2020		Septic tank plan
	Checked by	Eng. Abdul Wali Mustlih	Province	Faryab						

Section A-A

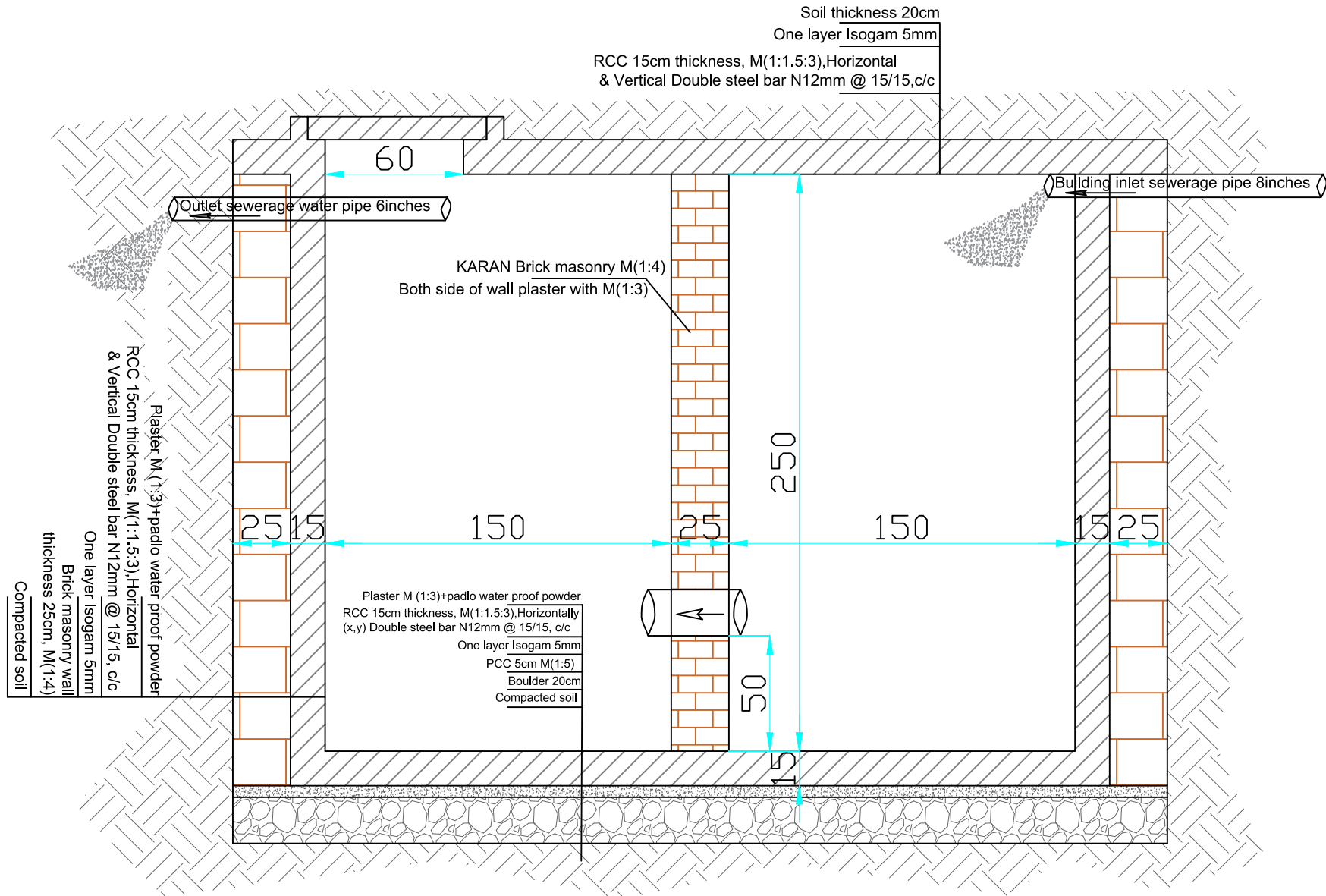

www.dacaar.org	Funded by	NMFA	Surveyed	Eng. Ab.Malik & Eng.Na.jmuddin	Village	Any	All dimensions are in Cm	Date	12/12	Drawing Title
	Implemented by	DACAAR	Designed	Eng. Abdul Malik Yosufzal	District	Any		April.2020		Septic tank plan
	Checked by	Eng. Abdul Wali Mustlih	Province	Faryab						