



# ORGANIZATION FOR RELIEF DEVELOPMENT ORD

---

## SPECIFIC PROCUREMENT NOTICE REQUEST FOR QOUTATION

RFQ No.: AFG/ORD/20/04

### Bid Documents for Supply and Installation Solar System for (Pipe Scheme) Balkh

Location: Firdausi Township, Balkh Province, Afghanistan

**ISSUANCE DATE: 18 JUNE, 2020**

**(Deadline for Submission of Bid): July 09, 2020, 16:00hrs (Afghanistan local time).**

YOUR O SEALED BIDS SHALL COMPRISE THE FOLLOWING TWO  
SETS OF DOCUMENTS MARKED:

“TECHNICAL BID” AND “FINANCIAL BID”  
IN SEPARATE ENVELOPES

Please ensure to sign the registration sheet at the ORD office while submitting sealed  
Bid!

**Subject:** Request for Quotation  
**Projects Name:** Supply and installation solar panels system for pipe scheme Balkh  
**Invitation to Bid No.:** AFG/ORD/20/04  
**Location:** Firdausi Township, Balkh Province, Afghanistan  
**Issuance Date:** June 18, 2020  
**Closing Date:** July 09, 2020

## **INTRODUCTION OF ORD**

Organization for Relief Development (ORD) is non-governmental, non-profit and non-political Organization that has been established in 2010, registered in Kabul, Afghanistan with the Islamic Republic of Afghanistan. ORD plays a critical role in providing management services for peace building, humanitarian assistance and development operations. These activities help suffering people in troubled parts of the Afghanistan. ORD's mission is to expand the capacity of its partners to implement peace building, humanitarian and development operations that matter for people in need. Working in some of the Afghanistan's most challenging environments, ORD vision is to always satisfy stakeholders with management services that meet better standards of quality, speed and cost effectiveness. By assisting its development partners, ORD makes significant, tangible contributions to results on the ground. For further information on ORD, its mandate and operations please see <http://www.ord.org.af>.

## **1. REQUEST FOR QOUTATION**

The Organization for Relief Development (ORD) is implementing partner of the United Nations High Commissioner for Refugees (UNHCR) for the Strengthening community resilience through participatory intervention to reduce protection risks and supporting Community Based Projects (CBP) projects with implementation in reintegration of returnees, IDPs and host Communities in North and Northeast region of Afghanistan.

## **2. REQUIRMENTS**

ORD, Mazar, invites qualified Construction Companies, duly registered with the Government of Afghanistan, to submit sealed bid for construction works "Supply and Installation Solar panels system for pipe scheme Balkh as per attached Technical BoQ, drawings and design of this document (Annexs-7 / 8).

It is recommended that this (RFQ) and its mandatory all annexes be read and fill it thoroughly. Otherwise failure to observe the procedure laid out there in my result in disqualification from the evaluation process.

## **3. ACKNOWLEDGEMENT**

We would appreciate your informing us of the receipt of this RFQ by return e-mail to: [procurement.nne@ord.org.af](mailto:procurement.nne@ord.org.af) or [procurement.ord@gmail.com](mailto:procurement.ord@gmail.com) that you will be submitting a bid.

#### **4. REQUESTS FOR CLARIFICATION**

Bidders are required to submit any request for clarification or any question in respect of this RFQ by e-mail to Supply Unit at [procurement.mne@ord.org.af](mailto:procurement.mne@ord.org.af) or [procurement.ord@gmail.com](mailto:procurement.ord@gmail.com)

The deadline for receipt of questions is 14:00 hrs local time on 05<sup>th</sup> July2020. Bidders are requested to keep all questions concise.

Please do not send bids to the above email address. Only queries questions on this RFQ can be sent to the subject line email (**Supply and installation solar system for pipe scheme Balkh – AFG/ORD/20/04**).

ORD will compile the questions received and plans to respond to such questions shortly after the closing date/time for clarifications. ORD may, at its discretion, copy any reply to a particular question to all other invited bidders at once.

#### **YOUR BID**

Your bid documents shall be prepared in English.

Please submit your bid using the Annexes provided. Bids not conforming to the requested formats may be not taken into consideration.

#### **5. ELIGIBLE BIDDERS:**

5.1 This Invitation for Bids is open for all interested companies who have registered with the government of Afghanistan and have valid license.

5.2 The company, organization or individual is not listed in the sanction and embargo list of the UN Security Council.

5.3 The company, organization or individual is not legally barred from the procurement process on the grounds of previous violations of regulations on fraud and corruption.

5.4 The company, organization or individual to will not be contracted for considerable portions of the contract is an enterprise economically intertwined with persons conducting the tender.

5.5 The bidder shall be an Afghan company registered with the government of Afghanistan.

#### **7. COST OF BIDDING**

The bidders shall bear all costs associated with the preparation and submission of their respective bids and the Employer will in no case be responsible or liable for those costs, regardless of the conduct or outcome of the bidding process.

#### **8. PERIOD OF PERFORMANCE**

All works for this project shall be completed as per submitting an authentic work plan before and after date of signing of the contract.

## **9. BIDDING DOCUMENTS**

The Bidding Documents, in addition to invitation for bids, are those stated below and all documents shall be signed /stamped by the bidder or his legally authorized representative and returned to the address according to the Bidding documents.

### **9.1 RFQ Documents**

The following annexes form integral part of this Invitation to Bid:

- Annex- 1: General Conditions of Contract
- Annex- 2: Vendor Registration Form
- Annex- 3: Summary of Relevant Work Experience
- Annex- 4: Technical Competence & Resources
- Annex- 5: Bid Form
- Annex- 6: Declaration of Undertaking
- Annex- 7: Financial Offer Form (Bill of Quantity)
- Annex- 8: Drawings

Prices must be quoted for all items in the Bill of Quantities.

The bidders are expected to examine carefully the contents of all the above documents.

Failure to comply with the requirements of bid submission will be at the Bidder's own risk, bids that are not substantially responsive to the requirements of the Bidding Documents will be rejected.

## **10. PREPARATION OF BID**

### **a. Documents Comprising the Bid**

Your bid documents should be enclosed the following two sets of documents:

- Technical bid
- Financial bid price

### **b. Content of the Technical Bid**

The submitted bid must include the following formation. Failure to supply all requested information or comply with the specific formats may disqualify the bidder from consideration. No Financial bid price should be included in the Technical Bid. Failure to comply may risk disqualification. The technical bid should contain all information required.

Your technical bid should be concisely presented and structured in the following order to include, but not necessarily be limited to, the following information:

- General conditions of contract in accordance of the Annex -1
- Vendor registration Form in accordance of the Annex - 2.
- Summary of relevant work experience in accordance of the Annex - 3.
- Technical Competence & Resources in accordance of the Annex - 4.
- Bid Form in accordance of the Annex - 5.
- Declaration of undertaking in accordance of the Annex -6.
- Drawings in accordance of the Annex -8.
- Past experience in providing construction services.
- Company profile with relevant past experience with (list and copy of contract for similar completed projects provided to UN/NGO entities; with copy of valid business license
- Confirm that your proposal is valid for 60 calendar days from the closing date of this RFQ in the Bid Form as Annex -5.
- Proposed time schedule and the timeframe that the contractor should be completed the project. Detailed Work Plan, including all major BoQ activities and allotment of resources for each project milestone. Proposed schedule shall be prepared in calendar days. Do not indicate dates, use only durations. The plan must cover the period from signing of the contract to site clearance, resources supply, delivery and completion and commissioning / hand-over to ORD of the required works.
- List of qualification and experience of the key and technical personnel of the company.
- List of equipment of the company (owned or rented).
- Other important documents, bidders feel need to be attached to support their bid.

### **c. Content of the Financial Bid Price**

- All prices shall be stated with applicable tax (in accordance with the current tax laws of the Islamic Republic of Afghanistan, and all other relevant provisions of the same law).
- All unit prices shall be indicated in the spaced provided in the price sheet (BoQ). The bidder must sign and officially stamp the Financial Offer Form or (BoQ).
- The offer should follow the given structure and prices shall be quoted in Afghani (AFN)
- The Financial bid price is to be submitted as per the BoQ or Financial Offer Form (Annex - 7). Bids that have a different price structure may not be accepted.
- Bid Validity Period Bids shall be valid for 60 calendar days from after the closing date of this RFQ. In exceptional circumstances, prior to expiry of the original bid validity period, the Employer may request that the bidders extend the period of validity for a specified additional period which shall in no case be more than the original bid validity period. The request and the responses thereto shall be made in writing.
- All Annexes of the bid are to be properly completed, signed and stamped.
- Each bidder shall prepare by filling out the forms completely and without alterations one Original specified in the bidding documents to comprising the bid and clearly mark them **“ORIGINAL”**

### **d. Alternative Bid**

Alternative bids are not allowed to be attached.

## **11. SUBMISSION OF BID**

- a. Deadline for submission of bid:

The closing date for submission of bids is 09<sup>th</sup> of July 2020, 16:00hrs (Afghanistan local time). Late bids shall be rejected and electronic submission is not allowed.

In case of emergencies and formal holidays it's extendable for one day more that bidders can submit their offers for the tomorrow of the closing date for submission of bid.

- b. Bids must be received by the Employer at the address specified no later than the deadline.  
c. Bids with charge payable will not be accepted, nor will arrangements be undertaken to collect the bids from any delivery point other than that specified above. Bidders shall bear all expenses incurred in the preparation and delivery of bids. No claims will be entertained for refund of such expenses.

## **12. SUBMISSION, SEALING AND MARKING OF BIDS**

Technical bid and the Price bid must be submitted as separately in sealed envelopes.

The signed and stamped bid one original including with its all attachments shall be submitted in a sealed envelope.

The envelope of your bidding documents shall be marked as following:

### **12.1 Bidding documents - Technical Bid for:**

Supply and installation solar panels system in Balkh province.

**Request for Quotation No.: AFG/ORD/20/04**

### **12.2 Bidding documents - Price Bid for:**

Supply and installation solar panels system in Balkh province.

**Request for Quotation No.: AFG/ORD/20/04**

### **12.3 The Employer's addresses for submission of the bids is:**

#### **ORD Regional Office:**

ORD Regional Office | Street # 2 | Kart-e-Shafakhana | Mazar-i-Sharif, Balkh province of Afghanistan

Phone No.: + 93 (0) 72 889 49 32 only for specifying of address.

## **13. MODIFICATION, SUBSTITUTION AND WITHDRAWAL OF BIDS**

The bidder may modify, or withdraw its bid after bid's submission, provided that the written notice of the modification, including substitution or withdrawal of the bids, received by the Employer prior to the deadline for submission of bids.

The Bidder's modification or withdrawal notice shall be prepared, sealed, marked, and dispatched. No bid may be modified by a bidder after the deadline for submission of bids.

## **14. BID OPENING AND EVALUATION**

### **14.1 Bid Opening**

The opening of the bid will be held with ORD members only. The bid opening will take place at: ORD regional Office, Mazar-I-Sharief, and the bid opening process will be held (in absence of the company's representative).

### **14.2 Process to be Confidential**

Information relating to the examination, clarification, evaluation and post-qualification of bids and recommendations for the award of a contract shall not be disclosed to bidders or any other person not officially concerned with such process before the announcement of bid evaluation report.

Any effort by a bidder to influence ORD in the examination, evaluation, comparison, and post qualification of the bids or contract award decisions may result in the rejection of its bid.

### **14.3 Examination of Bids and Determination of Responsiveness**

Prior to the detailed evaluation of bids, the Employer will determine whether each bid is substantially responsive to the requirements of the Bidding Documents.

A substantially responsive bid is one, which meets the eligibility criteria; has been properly signed; and conforms to all the terms, conditions and specifications of the bidding documents, without material deviation or reservation.

### **14.4 Technical and Financial evaluation**

Bids will be evaluated in accordance with the following technical criteria. Evaluation is made on a technical and financial basis. The percentage assigned to each component is determined in advance as follows:

The Technical bid documents will be evaluated by using of the following two stage criteria:

#	Technical Evaluation Criteria	Max Points Obtainable	
		Pass	Fail
<b>1 - First Stage Evaluation: PASS / FAIL Criteria</b>		Pass	Fail
1	Submission of a valid business license for purchasing and construction materials works with registered with Ministry of Commerce.	Pass	Fail
2	Bank details under the company name in (AFN)	Pass	Fail
3	Bidder accepts, and filled, completed, signed / stamped all ORD (Annexes).	Pass	Fail
4	Accepts proposal validity of 60 calendar days from closing date of this RFQ.	Pass	Fail



<b>2 - Second Stage Evaluation:</b>		<b>Scoring Criteria</b>
1.0	<b>Similar Past experience:</b> Years of experience in supplying and installation solar system for similar projects, list and contact details of references, incl. Donors/NGOs & Government with indication of provable evidence documents in last five years as prime contractor as described in (Annex – 3)	20
2.0	<b>Work plan (time schedule):</b> Provide a comprehensive work plan / time schedule for the purchasing and delivery of the intended project.	15
3.0	<b>Supply installation solar system warranty:</b> Clarity on origin / brand names of the proposed materials.	5
4.0	<b>Warranty:</b> Inclusion of specification of the proposed materials (eg. Type and quality of equipment / materials).	5
5.0	<b>Financial Capability:</b> Potential financial capacity to fund the milestones (in absence of advance payment by ORD), such as updated bank statement which should show source of the support project.	15
<b>Total</b>		<b>60</b>

**Note:** The Technical offer score will be calculated according to the percentage distribution for the technical and financial offers.

**In order to proceed to further stages of the evaluation process, the submitted proposal must obtain minimum 40 points or above of the total technical obtainable score, 60 points.**

#### **Financial Bid:**

The Financial Offer will use the following percentage distribution: 40% from the total score and the (lowest price) will be preferred.

The maximum number of points will be allotted to the lowest price offer that is opened and compared among those invited firms. All other price offers will receive points in inverse proportion to the lowest price; e.g.,  $[\text{total Price Component}] \times [\text{AFN lowest}] \div [\text{AFN other}] = \text{points for other supplier's Price Component}$ .

#### **14.5 Notification of Award**

Prior to the expiration of the period of bid validity, the Employer will notify the successful bidder in writing or where necessary by phone that his/her bid has been accepted.

#### **14.6 Award of Contract**

Prior to the expiration of the period of bid validity, ORD shall send the successfully letter to the winner bidder for the signing of contract / purchase order which constitute the notification of award.



## **14.7 Warranty Retainer**

A total of 10% of the full/total contract's amount will be retained for a period of 6 months as a retention fee. The amount shall be deducted from each interim invoice / payment. The retainer will be released after the expiry of the warranty period (defects and liabilities period), 6 months after completion and acceptance.

## **15. Payment Schedule**

All services included in this RFP and the subsequent contract will be paid as per the executed amount of work at each stage completion. All payments will be made in the currency of offer (and PO) and in accordance with the ORD General Conditions for the Purchase of Services.

Invoices will be settled after the completion and acceptance of the milestone deliverables.

All payments shall be technically endorsed by the ORD Project Manager / Logistic and approved by the ORD regional office in Mazar province.

### **15.1 Advance Payments**

Advance payments are not applicable for this tender and subsequent contract.

ORD has zero tolerance for fraud. Fraud is any act or mission that intentionally misleads, or attempts to mislead, to obtain a benefit or to avoid an obligation.

### **Attachments:**

- Annex- 1: General Conditions of Contract
- Annex- 2: Vendor Registration Form
- Annex- 3: Summary of Relevant Work Experience
- Annex- 4: Technical Competence & Resources
- Annex- 5: Bid Form
- Annex- 6: Declaration of Undertaking
- Annex- 7: Financial Offer Form (Bill of Quantity)
- Annex- 8: Drawings

**1. PURCHASE OF GOODS**

1.1 DELIVERY OF GOODS: The Contractor shall hand over or make available the goods, and ORD shall receive the goods, at the place for the delivery of the goods and within the time for delivery of the goods specified in the Contract. All manuals, instructions, displays and any other information relevant to the goods shall be in the English language unless otherwise specified in the Contract. Unless otherwise stated in the Contract (including, but not limited to, in any “INCOTERM” or similar trade term), the entire risk of loss, damage to, or destruction of the goods shall be borne exclusively by the Contractor until physical delivery of the goods to ORD in accordance with the terms of the Contract. Delivery of the goods shall not be deemed in itself as constituting acceptance of the goods by ORD.

1.2 INSPECTION OF THE GOODS: If the Contract provides that the goods may be inspected prior to delivery, the Contractor shall notify ORD when the goods are ready for pre-delivery inspection. Notwithstanding any pre-delivery inspection, ORD or its designated inspection agents may also inspect the goods upon delivery in order to confirm that the goods conform to applicable specifications or other requirements of the Contract. All reasonable facilities and assistance, including, but not limited to, access to drawings and production data, shall be furnished to ORD or its designated inspection agents at no charge therefore. Neither the carrying out of any inspections of the goods nor any failure to undertake any such inspections shall relieve the Contractor of any of its warranties or the performance of any obligations under the Contract.

1.3 ACCEPTANCE OF GOODS: Under no circumstances shall ORD be required to accept any goods that do not conform to the specifications or requirements of the Contract. ORD may condition its acceptance of the goods upon the successful completion of acceptance tests as may be specified in the Contract or otherwise agreed in writing by the Parties. In no case shall ORD be obligated to accept any goods unless and until ORD has had a reasonable opportunity to inspect the goods following delivery. If the Contract specifies that ORD shall provide a written acceptance of the goods, the goods shall not be deemed accepted unless and until ORD in fact provides such written acceptance. In no case shall payment by ORD in and of itself constitute acceptance of the goods. constitute acceptance of the goods.

2. REJECTION OF GOODS: Notwithstanding any other rights of, or remedies available to ORD under the Contract, in case any of the goods are defective or otherwise do not conform to the specifications or other requirements of the Contract, ORD, at its sole option, may reject or refuse

to accept the goods, and within thirty (30) days following receipt of notice from ORD of such rejection or refusal to accept the goods, the Contractor shall, in sole option of ORD:

- 2.1 Provide a full refund upon return of the goods, or a partial refund upon a return of a portion of the goods, by ORD; or,
  - 2.2 repair the goods in a manner that would enable the goods to conform to the specifications or other requirements of the Contract; or,
  - 2.3 replace the goods with goods of equal or better quality; and,
  - 2.4 pay all costs relating to the repair or return of the defective goods as well as the costs relating to the storage of any such defective goods and for the delivery of any replacement goods to ORD.
3. In the event that ORD elects to return any of the goods for the reasons specified in Article 6.7, above, ORD may procure the goods from another source. In addition to any other rights or remedies available to ORD under the Contract, including, but not limited to, the right to terminate the Contract, the Contractor shall be liable for any additional cost beyond the balance of the Contract price resulting from any such procurement, including, inter alia, the costs of engaging in such procurement, and ORD shall be entitled to compensation from the Contractor for any reasonable expenses incurred for preserving and storing the goods for the Contractor's account.
4. **TITLE:** The Contractor warrants and represents that the goods delivered under the Contract are unencumbered by any third party's title or other property rights, including, but not limited to, any liens or security interests. Unless otherwise expressly provided in the Contract, title in and to the goods shall pass from the Contractor to ORD upon delivery of the goods and their acceptance by ORD in accordance with the requirements of the Contract.

## **5. ASSIGNMENT AND SUBCONTRACTING**

### **5.1 Assignment of Contract**

The Contractor shall not, except after obtaining the prior written approval of the Employer, assign, transfer, pledge or make other disposition of the Contract or any part thereof or of any of the Contractor's rights, claims or obligations under the Contract.

### **5.2 Subcontracting**

In the event the Contractor requires the services of subcontractors, the Contractor shall obtain the prior written approval of the Employer for all such subcontractors. The approval of the Employer shall not relieve the Contractor of any of his obligations under the Contract, and the terms of any subcontract shall be subject to and be in conformity with the provisions of the Contract.

### **5.3 Assignment of Subcontractor's Obligations**

In the event of a subcontractor having undertaken towards the Contractor in respect of the work executed or the goods, materials, Plant or services supplied by such subcontractor for the Works, any continuing obligation extending for a period exceeding that of the Defects Liability Period under the Contract, the Contractor shall at any time after the expiration of such Period, assign to the Employer, at the Employer's request and cost, the benefit of such obligation for the unexpired duration thereof.

### **6. INSURANCE OF WORKS, ETC.**

The insurance coverage does not in this document applicable to all the types of insurance will be occurred in the project site. Hereof, against all loss or damage from whatever cause arising against loss or damage for which the Contractor is responsible.

The Employer shall not be liable for or in respect of any damages or compensation payable at law in respect or in consequence of any accident or injury to any workman or other person in the employment of the Contractor or any sub-Contractor, save and except an accident or injury resulting from any act or default of the Employer, his agents or servants. The Contractor shall indemnify, hold and save harmless the Employer against all such damages and compensation, save and except as aforesaid, and against all claims, proceedings, costs, charges and expenses whatsoever in respect thereof or in relation thereto.

### **7. OPPORTUNITIES FOR OTHER CONTRACTORS**

The Contractor shall in accordance with the requirements of the Engineer afford all reasonable opportunities for carrying out their work to any other contractors employed by the Employer and their workmen and to the workmen of the Employer and of any other duly constituted authorities who may be employed in the execution on or near the Site of any work not included in the Contract or of any contract which the Employer may enter into in connection with or ancillary to the Works. If work by other contractors of the Employer as above-mentioned involves the Contractor in any direct expenses as a result of using his Site facilities, the Employer shall consider payment to the Contractor of such sum or sums as maybe recommended by the Engineer.

### **8. CONTRACTOR TO KEEP SITE CLEAN**

During the progress of the Works, the Contractor shall keep the Site reasonably free from all unnecessary obstruction and shall store or dispose of any Constructional Plant and surplus

materials and clear away and remove from the Site any wreckage, rubbish or Temporary Works no longer required.

#### **9. CLEARANCE OF SITE ON SUBSTANTIAL COMPLETION**

On the substantial completion of the Works, the Contractor shall clear away and remove from the Site all Constructional Plant surplus materials, rubbish and Temporary Works of every kind and leave the whole of the Site and Works clean and in a workmanlike condition to the satisfaction of the Engineer.

#### **10. LABOUR**

Engagement of Labour, the Contractor shall make his own arrangements for the engagement of all labour local or otherwise.

#### **11. SUPPLY OF WATER**

The Contractor shall provide on the Site to the satisfaction of the Engineer an adequate supply of drinking and other water for the use of the Contractor's staff and work people.

#### **12. ALCOHOLIC DRINKS OR DRUGS**

The Contractor shall comply with Government laws and regulations and orders in force as regards the import, sale, barter or disposal of alcoholic drinks or narcotics and he shall not allow or facilitate such importation, sale, gift, barter or disposal by his sub-contractors, agents or employees.

#### **13. EXTENSION OF TIME FOR COMPLETION**

If, subject to the provisions of the Contract, the Engineer orders alterations or additions in the Works in accordance with Clause 48 hereof, or if circumstances constituting force majeure as defined in the Contract have occurred, the Contractor shall be entitled to apply for an extension of the time for completion of the Works specified in the Contract. The Employer shall, upon such application, determine the period of any such extension of time; provided that in the case of alterations or additions in the Works, the application for such an extension must be made before the alterations or additions in the Works are undertaken by the Contractor.

#### **14. LIQUIDATED DAMAGES FOR DELAY**

a) If the Contractor shall fail to complete the Works within the time for completion prescribed in the Contract, or any extended time for completion in accordance with the Contract, then the Contractor shall pay to the Employer the sum specified in the Contract as liquidated damages,

for the delay between the time prescribed in the Contract or the extended time for completion, as the case may be, and the date of substantial completion of the Works as stated in the Certificate of Substantial Completion, subject to the applicable limit stated in the Contract. The said sum shall be payable by the sole fact of the delay without the need for any previous notice or any legal proceedings, or proof of damage, which shall in all cases be considered as ascertained. The Employer may, without prejudice to any other method of recovery, deduct the amount of such liquidated damages from any monies in its hands due or which may become due to the Contractor. The payment or deduction of such damages shall not relieve the Contractor from his obligation to complete the Works or from any other of his obligations and liabilities under the Contract.

b) If, before the time for completion of the whole of the Works or of a Section of the Works, a Certificate of Substantial Completion has been issued for any part or Section of the Works, the liquidated damages for delay in completion of the remainder of the Works or of that Section may, for any period of delay after the date stated in such Certificate of Substantial Completion, and in the absence of alternative provisions in the Contract, be reduced in the proportion which the value of the part or Section so certified bears to the total value of the whole of the Works or Section, as applicable. The provisions of this Sub-Clause shall only apply to the rate of liquidated damages and shall not affect the limit thereof.

## **15. FORCE MAJEURE**

Force majeure as used herein means Acts of God, war (whether declared or not), invasion, revolution, insurrection or other acts or events of a similar nature or force.

In the event of and as soon as possible after the occurrence of any cause constituting force majeure, the Contractor shall give notice and full particulars in writing to the ORD and to the Engineer of such force majeure if the Contractor is thereby rendered unable, wholly or in part, to perform its obligations and meet its responsibilities under this Contract. Subject to acceptance by the ORD of the existence of such force majeure, which acceptance shall not be unreasonably withheld, the following provisions shall apply:

(a) The obligations and responsibilities of the Contractor under this Contract shall be suspended to the extent of his inability to perform them and for as long as such inability continues. During such suspension and in respect of work suspended, the Contractor shall be reimbursed by the ORD substantiated costs of maintenance of the Contractor's equipment and of per diem of the Contractor's permanent personnel rendered idle by such suspension;

(b) The Contractor shall within fifteen (15) days of the notice to the ORD of the occurrence of the force majeure submit a statement to the ORD of estimated costs referred to in sub-paragraph (a)

above during the period of suspension followed by a complete statement of actual expenditures within thirty (30) days after the end of the

(c) Suspension;

(d) The term of this Contract shall be extended for a period equal to the period of suspension taking however into account any special condition which may cause the additional time for completion of the Works to be different from the period of suspension;

(e) If the Contractor is rendered permanently unable, wholly or in part, by reason of force majeure, to perform his obligations and meet his responsibilities under the Contract, the ORD shall have the right to terminate the Contract on the same terms and conditions as provided for in Clause 68 of these General Conditions, except that the period of notice shall be seven (7) days instead of fourteen (14) days, and

(f) For the purpose of the preceding sub-paragraph, the ORD may consider the Contractor permanently unable to perform in case of any suspension period of more than ninety (90) days.

#### **16. TERMINATION BY THE ORD**

The ORD may, notwithstanding any suspension under Clause 67 above, terminate this Contract for cause or convenience in the interest of the ORD upon not less than fourteen (14) days written notice to the Contractor.

Upon termination of this Contract:

(a) The Contractor shall take immediate steps to terminate his performance of the Contract in a prompt and orderly manner and to reduce losses and to keep further expenditures to a minimum, and

(b) The Contractor shall be entitled (unless such termination has been occasioned by the Contractor's breach of this Contract), to be paid for the part of the Works satisfactorily completed and for the materials and equipment properly delivered to the Site as of the date of termination for incorporation to the Works, plus substantiated costs resulting from commitments entered into prior to the date of termination as well as any reasonable substantiated direct costs incurred by the Contractor as a result of the termination, but shall not be entitled to receive any other or further payment or damages.

#### **17. TERMINATION BY THE CONTRACTOR**

In the case of any alleged breach by the ORD of the Contract or in any other situation which the Contractor reasonably considers to entitle him to terminate his performance of the Contract, the

Contractor shall promptly give written notice to the ORD detailing the nature and the circumstances of the breach or other situation. Upon acknowledgement in writing by the ORD of the existence of such breach and the ORD' inability to remedy it, or upon failure of the ORD to respond to such notice within twenty (20) days of receipt thereof, the Contractor shall be entitled to terminate this Contract by giving 30 days written notice thereof. In the event of disagreement between the Parties as to the existence of such breach or other situation referred to above, the matter shall be resolved in accordance with Clause 71 of these General Conditions. Upon termination of this Contract under this Clause the provisions of sub-paragraph (b) of Clause 68 hereof shall apply.

#### **18. RIGHTS AND REMEDIES OF THE ORD**

Nothing in or relating to this Contract shall be deemed to prejudice or constitute a waiver of any other rights or remedies of the ORD.

The ORD shall not be liable for any consequences of, or claim based upon, any act or omission on the part of the Government.

#### **19. SETTLEMENT OF DISPUTES**

In the case of any claim, controversy or dispute arising out of, or in connection with this Contract or any breach thereof, the following procedure for resolution of such claim, controversy or dispute shall apply.

##### **20. Notification**

The aggrieved party shall immediately notify the other party in writing of the nature of the alleged claim, controversy or dispute, not later than seven (7) days from awareness of the existence thereof.

##### **21. Consultation**

On receipt of the notification provided above, the representatives of the Parties shall start consultations with a view to reaching an amicable resolution of the claim, controversy or dispute without causing interruption of the Works.

##### **22. Conciliation**

Where the representatives of the Parties are unable to reach such an amicable settlement, either party may request the submission of the matter to conciliation in accordance with the ORD Rules of Conciliation then obtaining.



## **23. PRIVILEGES AND IMMUNITIES**

Nothing in or relating to this Contract shall be deemed a waiver of any of the privileges and immunities of the ORD is an integral part.

## **24. CODE OF CONDUCT**

### **Basic Principles**

The Code of Conduct applies to all staff members. It also applies mutatis mutandis to development workers and integrated experts, meaning that it is incorporated into individual contractual agreements in a form specifically adapted to this group.

### **Orientation**

The Code of Conduct is based on our common corporate values as set out in the company's Corporate Principles. We, the ORD staff members, practice these principles ourselves and expect our subcontractors to do so too. It is our wish that our project partners and target groups respect our principles.

### **ORD employees are guided by the following principles**

- **Equal rights**  
We work with other people without any distinction in terms of gender, marital status, skin color, religion or world view, culture, education, social origin, disability, age, sexual identity or nationality.
- **Prohibition of sexual harassment**  
We do not tolerate any form of sexual harassment in the company.
- **Compliance with contract and statute**  
We fulfill our contractual agreements. We respect the law in Afghanistan and in our Partner countries.
- **Transparency**  
We make sure that our actions and motives are clear and comprehensible.
- **Loyalty**  
We are loyal to our company, the federally owned ORD. This also means providing constructive criticism, which we express in an appropriate manner, first of all within ORD.
- **Confidentiality**  
We maintain secrecy towards unauthorised parties about matters concerning the company, its business partners, cooperation partners and other third parties that have come to our attention through our work for the company. The obligation to maintain secrecy also applies after the termination of a contract of employment. It does not apply to information that is in the public domain or which in terms of significance does not require secrecy.

**VENDOR REGISTRATION FORM**  
**Company Details and General Information**

The information provided in response to this questionnaire will be held confidential by ORD for use only in Supplier Evaluation and not disclosed to any outside party without your prior written consent. Please provide the following information:

1. Name of supplier	
2. Address of supplier	
3. Contact name	
4. Telephone number	
5. Mobile number	
6. Email address	
7. Website address	
8. What are your opening hours/days?	
9. Company registration number	
10. Year of company registration	
11. Please attach company registration documentation	
12. Annual turnover of your company	
13. Number of employees in your company	
14. Name of bank	
15. Bank details	
16. What products and services do you supply?	
17. Are you able to provide samples of your goods?	
18. What warranties/repair services do you offer?	
19. What storage or stock capacity do you have?	
20. Please provide references of other aid agency customers you have supplied with goods or services.	
21. Do you have a health and safety policy?	

It should be noted that the answers you provide to this questionnaire might influence your potential relationship with ORD. Following completion, signature, and submission of this questionnaire any subsequent changes must be submitted to ORD in writing immediately.

**SUMMARY OF RELEVANT CAPABILITY, EXPERIENCE AND PAST PERFORMANCE**

Include projects that best illustrate your experience relevant to this (RFQ) or similar activities, sorted by decreasing order of completion date.

Projects should have been undertaken in the past three years. Projects undertaken in the past Five years may be taken into consideration at the discretion of the evaluation panel.

No.	Project Title and Description of Activities	Location Province/District	Client Name/ Email/Tel #	Cost in US\$/AFN	Start Dates	End Dates	Completed Schedule (Yes/No)	Subcontract or or Prime Contractor?
1								
2								
3								
4								
5								

Bidder may attached their summary of relevant experience list as computerized that received goods and/or services of a nature similar to the requirements of this RFQ

**TECHNICAL COMPETENCE & RESOURCES**

**1. Personnel Resources** – Please list your organization’s key personnel in the below tables **Table (1)**:

**1.1 Number of Staff:**

	Managerial	Technical	Operative	Administrative	Other (specify)
Nos.					

**1.2 List the key and technical staff** (not more than five persons)

Key and technical Personnel				
No	Name	Position	Date of Joining company	Year of Experience
Proposed staff for completion of the intended project				
Name	title	Years with company	Experience & Job responsibility	

**2. Staff CVs** – Please provide your company organization chart and CVs for all key and technical personnel (CVs for the listed personnel in Table 1.2 is mandatory).

1	Name:	
2	Gender	
3	Date of Birth:	
4	Nationality	
5	Position in the organization:	



6	Education	
7	Professional affiliation/membership of professional bodies.	
8	Professional trainings (Indicate significant training since degrees under 7/above)	
9	Language skills	
10	Work experience [Starting with present position, list in reverse order with name of organization and position held by staff)	

**3. Equipment and Machinery:** please provide the list with submission of provable evidence.

**Table (3)**

<b>Equipment</b>					
Type / Description / Model	Size /Capacity	Number	Current Location	Own or Leased	Age

Note: add additional row if needed.



## Bid FORM

Annex- 5

**RFQ No.: AFG/ORD/20/04**

**Project Name: Supply and installation of solar panels system for pipe scheme Balkh**

**Company Name:** \_\_\_\_\_

**To:** ORD Regional Office, Mazar-I-Sharief

Dear Sir or Madam,

1. Having examined the Conditions of Contract, and Bill of Quantities and all other documents received with the Invitation to Bid for the execution of the Works in connection with the above named Project, we, the undersigned offer to execute and complete such Works and remedy any faults and defects therein in conformity with the conditions spelled out in the afore-mentioned documents for the sum of as mentioned in Price Proposal.

Or such other sums as may be ascertained in accordance with the said conditions.

2. We undertake, if our Tender is accepted, to commence the Works within the time required in the contract conditions, and to complete the whole of the Works comprised in the contract within the time stated in the Contract Conditions.
3. We agree to abide by this Bid for the period of **60 calendar days** from the submission/opening date stated in the Invitation to Bid and it shall remain binding upon us and may be accepted at any time before the expiration of that period.
4. Unless and until a Contract Agreement is signed, this Bid, together with your written acceptance thereof, shall constitute a binding contract between us.
5. We understand that you are not bound to accept the lowest or any Bid you may receive.

Dated this:..... day of: .....

Signature:..... in the capacity of .....

duly authorized to sign Bid for and on behalf of

.....  
(Bidder name and address in block capitals)

### Declaration of Undertaking

Invitation to Bid No.: AFG/ORD/20/04

Project Name: **Supply and installation of solar panels system for pipe scheme Balkh**

We underscore the importance of a free, fair and competitive procurement process that precludes fraudulent use. In this respect we have neither offered nor granted, directly or indirectly, any inadmissible advantages to any public servants or other persons in connection with our bid, nor will we offer or grant any such incentives or conditions in the present procurement process or, in the event that we are awarded the contract, in the subsequent execution of the contract.

We also underscore the importance of adhering to minimum social standards ("Core Labour Standards") in the implementation of the project. We undertake to comply with the Core Labour Standards ratified by the country of Afghanistan.

We will inform our staff about their respective obligations and about their obligation to fulfill this declaration of undertaking and to obey the laws of the country of Afghanistan.

We also declare that our company/all members of the consortium has/have not been included in the list of sanctions of the United Nations, nor of the EU, nor in any other list of sanctions and affirm that our company/all members of the consortium will immediately inform the client if this situation should occur at a later stage.

We acknowledge that, in the event that our company (or a member of the consortium) is added to a list of sanctions that is legally binding upon the client, the client is entitled to exclude our company/the consortium from the procurement procedure and, if the contract is awarded to our company/the consortium, to terminate the contract immediately if the statements made in the Declaration of Undertaking were objectively false or the reason for exclusion occurs after the Declaration of Undertaking has been issued.

(Place) ....., this ..... day of .....

Name of company: \_\_\_\_\_

Signature: \_\_\_\_\_ Mobile No. \_\_\_\_\_

Seal: \_\_\_\_\_ Email address \_\_\_\_\_



## FINANCIAL OFFER FORM

**Project Title:** Supply and Installation Solar System for (Pipe Scheme) Balkh province

**Annex -7**

**Location:** Firdausi Township, Balkh Province, Afghanistan

**Subject:** BoQ for solar system

**Date:** 31/03/2020

**Project Code:** AFG/ORD/20/04

No.	Description	Unit	Quantity	Unit cost [AFN]	Amount [AFN]	Remarks
1	Water pump, SP 5A-52 (SP5A-52 3*220v5.5kw 05171k52) Product No: 05171K52 that can pump 2.5-3 liter/ sec from depth of 200m with horizontal length of 2500 m or or <b>similar standard products</b> by reputable brand or manufactures which accepted by Afghanistan government MRRD.	Each	1			
2	Solar inverter GRUNDFOS SP5A-52 3*220v5.5kw 05171k52 or or <b>similar standard products</b> by reputable brand or manufactures which accepted by Afghanistan government MRRD.	set	1			
3	GRUNDFOS GF270 W 9909912 mono crystal solar panel or <b>similar standard products</b> by reputable brand or manufactures which accepted by Afghanistan government MRRD.	Panel	39			
4	Cable 4*6mm	m	200			
5	Cable 2*6mm for float switch	m	2500			
6	Float switch start/ stop water storage tank	Pcs	1			
7	Box for Inverter (for Humadity and dust protection) (size 60cmx50cmx35)	Pcs	1			
8	FUSE 690V automatic	set	1			
9	Ground Rod (D=16mm, L=1.5m)	Pcs	1			
10	Ground cable (1*10) Flexeble Copper inside	m	100			
11	Conduit Pipe For wire (D=25mm)	m	100			
12	Safety Rope for Pump	m	300			
13	Stand for solar panels (Good Quality steel)	set	1			
14	Transportation charges	job	1			
15	Installation	job	1			

**TOTAL**

Company Name:

Date:

Signature (Name / Position):

Mobile No:

Email Address:

Stamp / Seal:

Total Price in words (AFN) -



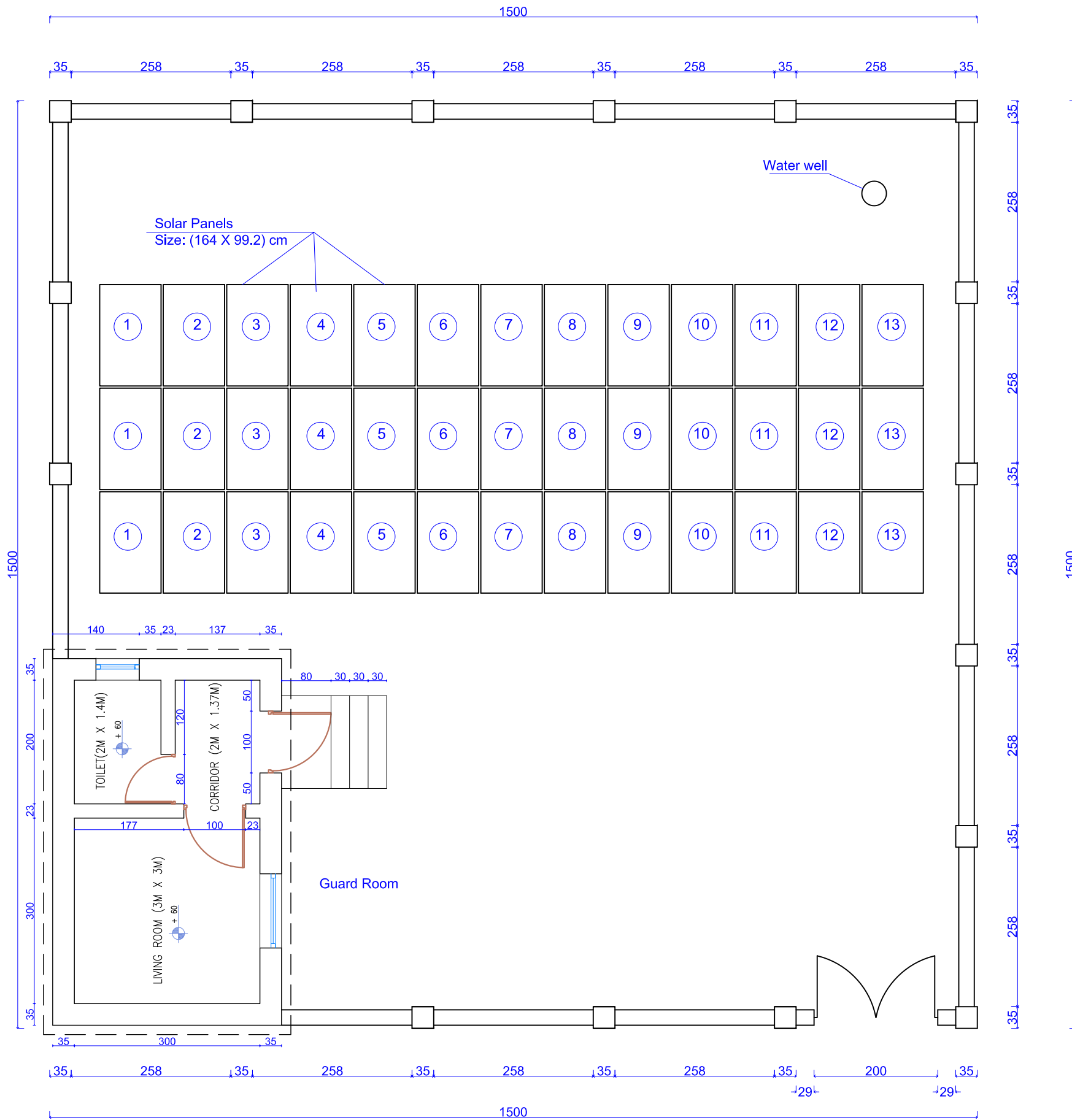

Plan of Boundary Wall  
Scale 1:75

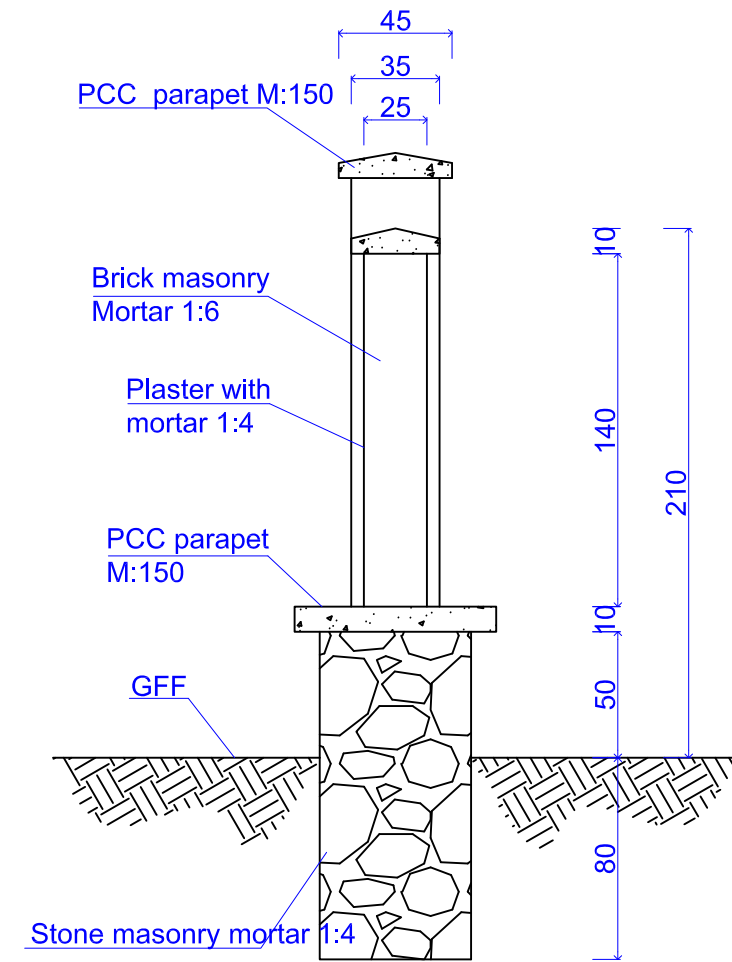

Section B-B

UNLESS NOTED OTHERWISE, LINEAR DIMENSIONS SHOWN ARE IN CENTIMETER.

PROJECT TITLE		WATER NETWORK PIPE		PROVINCE		LOCATION		APPROVER	
DRAWING TITLE		BOUNDARY WALL AND GUARD ROOM		DISTRICT		MAZAR		UNHCR	
SECTION/SHEET#		ARCHITECTURAL / 01		VILLAGE		FIRDAUSI		UNHCR	
DESIGNED BY		UNHCR SOM & WAW		BALKH		MAZAR		UNHCR	
DRAWN BY		UNHCR SOM		E		H		UNHCR	
CHECKED BY		UNHCR SOM		H		H		UNHCR	
SCALE		1:75 & 30		N		00' 00"		UNHCR SUB OFFICE MAZAR-E-SHARIF	
UNIT		CM		E		S		ACCESS TO SERVICES	
DATE:		04/19/2020		H		H		UNHCR	
IMPLEMENTER				H		H		UNHCR	

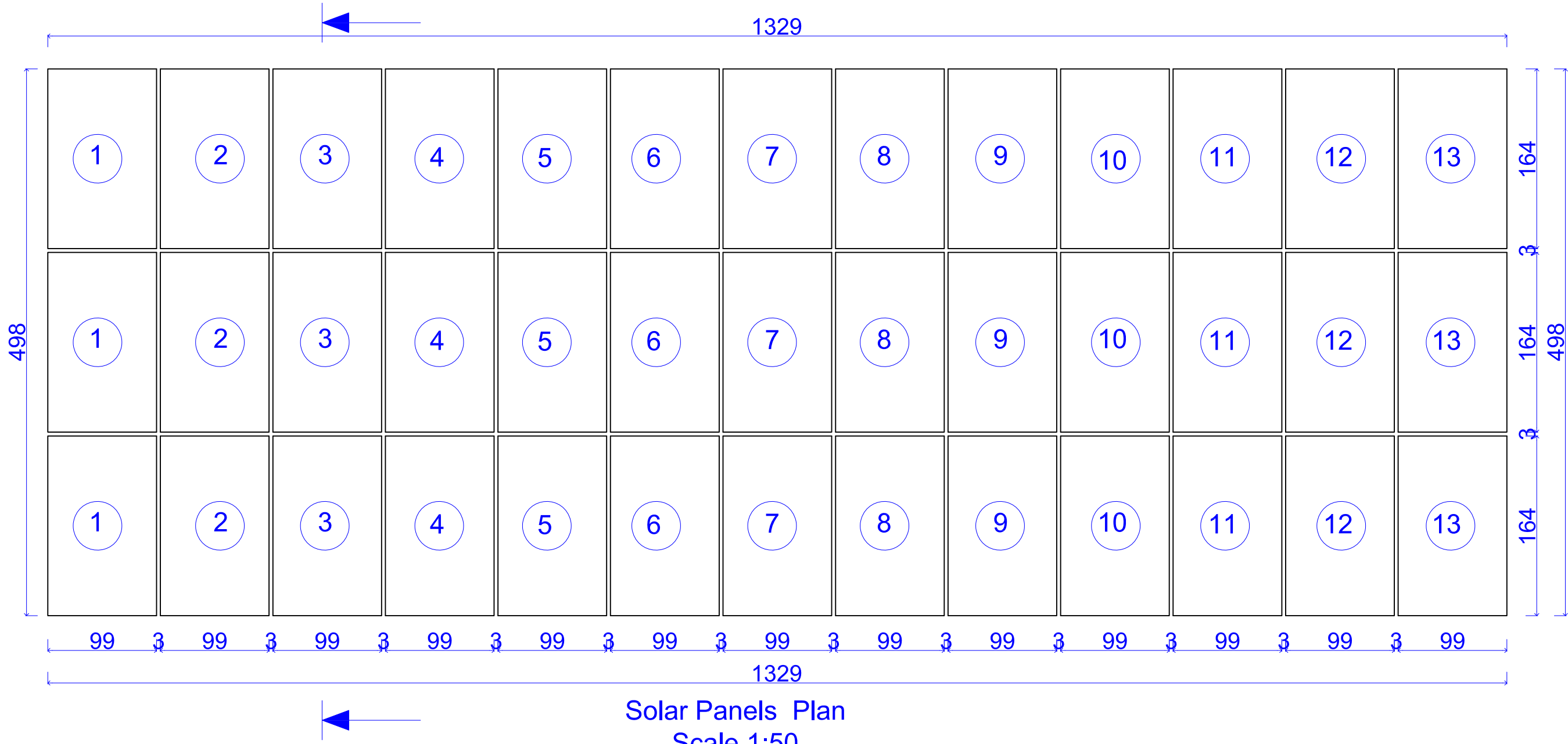

Solar Panels Plan  
Scale 1:50

UNLESS NOTED OTHERWISE, LINEAR DIMENSIONS SHOWN ARE IN CENTIMETER.

		APPROVER		DATE: 04/19/2020		IMPLEMENTER	
		SECTION/SHEET#		ARCHITECTURAL / 04		DATE: 04/19/2020	
PROJECT TITLE	WATER NETWORK PIPE		SOLAR PANEL PLANS		ARCHITECTURAL / 04		
DRAWING TITLE	SOLAR PANEL PLANS		ARCHITECTURAL / 04		ARCHITECTURAL / 04		
LOCATION		PROVINCE	BALKH	DESIGNED BY	UNHCR SOM & WAW	PAPER SIZE	A4
LOCATION		DISTRICT	MAZAR	DRAWN BY	UNHCR SOM	SCALE	1:50
LOCATION		VILLAGE	FIRDAUSI	CHECKED BY	UNHCR SOM	UNIT	CM
LOCATION		GPS				DATE	04/19/2020
LOCATION		N	00' 00" 00"				
LOCATION		E					
LOCATION		H					
ACCESS TO SERVICES							
UNHCR SUB OFFICE MAZAR-E-SHARIF							